

SECTION **SE**
SEAT

A
B
C
D
E
F
G
H
I
SE
K
L
M
N
O
P

CONTENTS

<p>REGULAR GRADE</p> <p>SYMPTOM DIAGNOSIS 2</p> <p>SQUEAK AND RATTLE TROUBLE DIAGNOSES 2</p> <p> Work Flow 2</p> <p> Inspection Procedure 4</p> <p> Diagnostic Worksheet 6</p> <p>PRECAUTION 8</p> <p>PRECAUTIONS 8</p> <p> Precaution for Supplemental Restraint System (SRS) "AIR BAG" and "SEAT BELT PRE-TENSIONER" 8</p> <p> Service Notice 8</p> <p> Precaution for Work 8</p> <p>PREPARATION 10</p>	<p>PREPARATION 10</p> <p> Special Service Tool 10</p> <p> Commercial Service Tool 10</p> <p>REMOVAL AND INSTALLATION 11</p> <p>FRONT SEAT 11</p> <p> Exploded View 11</p> <p> Removal and Installation 13</p> <p> Disassembly and Assembly 13</p> <p>REAR SEAT 16</p> <p> Exploded View 16</p> <p> Removal and Installation 17</p> <p> Disassembly and Assembly 17</p> <p style="text-align: center;">Krom</p> <p>SPEC CHANGE INFORMATION 21</p> <p>SEAT 21</p> <p> Seat 21</p>
---	---

SYMPTOM DIAGNOSIS

SQUEAK AND RATTLE TROUBLE DIAGNOSES

Work Flow

INFOID:000000005492374

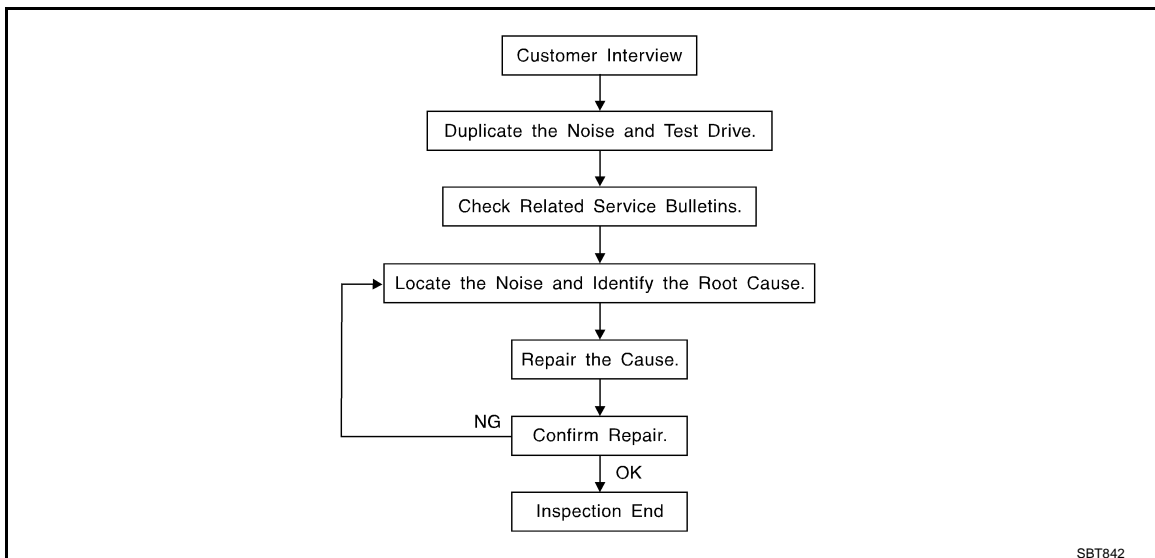

CUSTOMER INTERVIEW

Interview the customer if possible, to determine the conditions that exist when the noise occurs. Use the Diagnostic Worksheet during the interview to document the facts and conditions when the noise occurs and any of customer's comments; refer to [SE-6. "Diagnostic Worksheet"](#). This information is necessary to duplicate the conditions that exist when the noise occurs.

- The customer may not be able to provide a detailed description or the location of the noise. Attempt to obtain all the facts and conditions that exist when the noise occurs (or does not occur).
- If there is more than one noise in the vehicle, perform a diagnosis and repair the noise that the customer is concerned about. This can be accomplished by performing a cruise test on the vehicle with the customer.
- After identifying the type of noise, isolate the noise in terms of its characteristics. The noise characteristics are provided so the customer, service adviser and technician are all speaking the same language when defining the noise.
- Squeak – (Like tennis shoes on a clean floor)
Squeak characteristics include the light contact/fast movement/brought on by road conditions/hard surfaces = higher pitch noise/softer surfaces = lower pitch noises/edge to surface = chirping
- Creak – (Like walking on an old wooden floor)
Creak characteristics include firm contact/slow movement/twisting with a rotational movement/pitch dependent on materials/often brought on by activity.
- Rattle – (Like shaking a baby rattle)
Rattle characteristics include the fast repeated contact/vibration or similar movement/loose parts/missing clip or fastener/incorrect clearance.
- Knock – (Like a knock on a door)
Knock characteristics include hollow sounding/sometimes repeating/often brought on by driver action.
- Tick – (Like a clock second hand)
Tick characteristics include gentle contacting of light materials/loose components/can be caused by driver action or road conditions.
- Thump – (Heavy, muffled knock noise)
Thump characteristics include softer knock/dead sound often brought on by activity.
- Buzz – (Like a bumblebee)
Buzz characteristics include high frequency rattle/firm contact.
- Often the degree of acceptable noise level will vary depending up on the person. A noise that a technician may judge as acceptable may be very irritating to the customer.
- Weather conditions, especially humidity and temperature, may have a great effect on noise level.

DUPLICATE THE NOISE AND TEST DRIVE

SQUEAK AND RATTLE TROUBLE DIAGNOSES

< SYMPTOM DIAGNOSIS >

[REGULAR GRADE]

If possible, drive the vehicle with the customer until the noise is duplicated. Note any additional information on the Diagnostic Worksheet regarding the conditions or location of the noise. This information can be used to duplicate the same conditions when the repair is reconfirmed.

If the noise can be duplicated easily during the test drive, to help identify the source of the noise, try to duplicate the noise with the vehicle stopped by doing one or all of the following:

- 1) Close a door.
 - 2) Tap or push/pull around the area where the noise appears to be coming from.
 - 3) Rev the engine.
 - 4) Use a floor jack to recreate vehicle "twist".
 - 5) At idle, apply engine load (electrical load, half-clutch on M/T models, drive position on A/T models).
 - 6) Raise the vehicle on a hoist and hit a tire with a rubber hammer.
- Drive the vehicle and attempt to duplicate the conditions the customer states exist when the noise occurs.
 - If it is difficult to duplicate the noise, drive the vehicle slowly on an undulating or rough road to stress the vehicle body.

CHECK RELATED SERVICE BULLETINS

After verifying the customer concern or symptom, check ASIST for Technical Service Bulletins (TSBs) related to that concern or symptom.

If a TSB relates to the symptom, follow the procedure to repair the noise.

LOCATE THE NOISE AND IDENTIFY THE ROOT CAUSE

1. Narrow down the noise to a general area. To help pinpoint the source of the noise, use a listening tool (Chassis ear: J-39570, Engine ear and mechanics stethoscope).
2. Narrow down the noise to a more specific area and identify the cause of the noise by:
 - Removing the components in the area that is are suspected to be the cause of the noise.
Do not use too much force when removing clips and fasteners, otherwise clips and fastener can be broken or lost during the repair, resulting in the creation of new noise.
 - Tapping or pushing/pulling the component that is are suspected to be the cause of the noise.
Do not tap or push/pull the component with excessive force, otherwise the noise will be eliminated only temporarily.
 - Feeling for a vibration by hand by touching the component(s) that is are suspected to be the cause of the noise.
 - Placing a piece of paper between components that are suspected to be the cause of the noise.
 - Looking for loose components and contact marks.
Refer to [SE-4, "Inspection Procedure"](#).

REPAIR THE CAUSE

- If the cause is a loose component, tighten the component securely.
- If the cause is insufficient clearance between components:
 - Separate components by repositioning or loosening and retightening the component, if possible.
 - Insulate components with a suitable insulator such as urethane pads, foam blocks, felt cloth tape or urethane tape. A Nissan Squeak and Rattle Kit (J-43980) is available through the authorized Nissan Parts Department.

CAUTION:

Never use excessive force as many components are constructed of plastic and may be damaged.

NOTE:

Always check with the Parts Department for the latest parts information.

The following materials are contained in the Nissan Squeak and Rattle Kit (J-43980). Each item can be ordered separately as needed.

URETHANE PADS [1.5 mm (0.059 in) thick]

Insulates connectors, harness, etc.

76268-9E005: 100 × 135 mm (3.94 × 5.31 in)/76884-71L01: 60 × 85 mm (2.36 × 3.35 in)/76884-71L02: 15 × 25 mm (0.59 × 0.98 in)

INSULATOR (Foam blocks)

Insulates components from contact. Can be used to fill space behind a panel.

73982-9E000: 45 mm (1.77 in) thick, 50 × 50 mm (1.97 × 1.97 in)/73982-

50Y00: 10 mm (0.39 in) thick, 50 × 50 mm (1.97 × 1.97 in)

INSULATOR (Light foam block)

80845-71L00: 30 mm (1.18 in) thick, 30 × 50 mm (1.18 × 1.97in)

FELT CLOTHTAPE

Used to insulate where movement does not occur. Ideal for instrument panel applications.

SQUEAK AND RATTLE TROUBLE DIAGNOSES

< SYMPTOM DIAGNOSIS >

[REGULAR GRADE]

68370-4B000: 15 × 25 mm (0.59 × 0.98 in) pad/68239-13E00: 5 mm (0.20 in) wide tape roll

The following materials, not found in the kit, can also be used to repair squeaks and rattles.

UHMW (TEFLON) TAPE

Insulates where slight movement is present. Ideal for instrument panel applications.

SILICONE GREASE

Used in place of UHMW tape that is be visible or does not fit. Will only last a few months.

SILICONE SPRAY

Used when grease cannot be applied.

DUCT TAPE

Used to eliminate movement.

CONFIRM THE REPAIR

Confirm that the cause of a noise is repaired by test driving the vehicle. Operate the vehicle under the same conditions as when the noise originally occurred. Refer to the notes on the Diagnostic Worksheet.

Inspection Procedure

INFOID:000000005492375

Refer to Table of Contents for specific component removal and installation information.

INSTRUMENT PANEL

Most incidents are caused by contact and movement between:

1. The cluster lid A and instrument panel
2. Acrylic lens and combination meter housing
3. Instrument panel to front pillar garnish
4. Instrument panel to windshield
5. Instrument panel mounting pins
6. Wiring harnesses behind the combination meter
7. A/C defroster duct and duct joint

These incidents can usually be located by tapping or moving the components to duplicate the noise or by pressing on the components while driving to stop the noise. Most of these incidents can be repaired by applying felt cloth tape or silicon spray (in hard to reach areas). Urethane pads can be used to insulate wiring harness.

CAUTION:

Never use silicone spray to isolate a squeak or rattle. If the area is saturated with silicone, the recheck of repair becomes impossible.

CENTER CONSOLE

Components to pay attention to include:

1. Shifter assembly cover to finisher
2. A/C control unit and cluster lid C
3. Wiring harnesses behind audio and A/C control unit

The instrument panel repair and isolation procedures also apply to the center console.

DOORS

Pay attention to the following:

1. Finisher and inner panel making a slapping noise
2. Inside handle escutcheon to door finisher
3. Wiring harnesses tapping
4. Door striker out of alignment causing a popping noise on starts and stops

Tapping or moving the components or pressing on them while driving to duplicate the conditions can isolate many of these incidents. The areas can usually be insulated with felt cloth tape or insulator foam blocks from the Nissan Squeak and Rattle Kit (J-43980) to repair the noise.

TRUNK

Trunk noises are often caused by a loose jack or loose items put into the trunk by the customer.

In addition look for the following:

1. Trunk lid dumpers out of adjustment
2. Trunk lid striker out of adjustment

SQUEAK AND RATTLE TROUBLE DIAGNOSES

< SYMPTOM DIAGNOSIS >

[REGULAR GRADE]

3. The trunk lid torsion bars knocking together

4. A loose license plate or bracket

Most of these incidents can be repaired by adjusting, securing or insulating the item(s) or component(s) causing the noise.

SUNROOF/HEADLINING

Noises in the sunroof/headlining area can often be traced to one of the following:

1. Sunroof lid, rail, linkage or seals making a rattle or light knocking noise

2. Sunvisor shaft shaking in the holder

3. Front or rear windshield touching headlining and squeaking

Again, pressing on the components to stop the noise while duplicating the conditions can isolate most of these incidents. Repairs usually consist of insulating with felt cloth tape.

SEATS

When isolating seat noise it's important to note the position the seats in and the load placed on the seat when the noise occurs. These conditions should be duplicated when verifying and isolating the cause of the noise.

Cause of seat noise include:

1. Headrest rods and holder

2. A squeak between the seat pad cushion and frame

3. The rear seatback lock and bracket

These noises can be isolated by moving or pressing on the suspected components while duplicating the conditions under which the noise occurs. Most of these incidents can be repaired by repositioning the component or applying urethane tape to the contact area.

UNDERHOOD

Some interior noise may be caused by components under the hood or on the engine wall. The noise is then transmitted into the passenger compartment.

Causes of transmitted underhood noise include:

1. Any component mounted to the engine wall

2. Components that pass through the engine wall

3. Engine wall mounts and connectors

4. Loose radiator mounting pins

5. Hood bumpers out of adjustment

6. Hood striker out of adjustment

These noises can be difficult to isolate since they cannot be reached from the interior of the vehicle. The best method is to secure, move or insulate one component at a time and test drive the vehicle. Also, engine RPM or load can be changed to isolate the noise. Repairs can usually be made by moving, adjusting, securing, or insulating the component causing the noise.

A

B

C

D

E

F

G

H

I

SE

K

L

M

N

O

P

SQUEAK AND RATTLE TROUBLE DIAGNOSES

< SYMPTOM DIAGNOSIS >

[REGULAR GRADE]

Diagnostic Worksheet

INFOID:000000005492376



SQUEAK & RATTLE DIAGNOSTIC WORKSHEET

Dear Nissan Customer:

We are concerned about your satisfaction with your Nissan vehicle. Repairing a squeak or rattle sometimes can be very difficult. To help us fix your Nissan right the first time, please take a moment to note the area of the vehicle where the squeak or rattle occurs and under what conditions. You may be asked to take a test drive with a service advisor or technician to ensure we confirm the noise you are hearing.

I. WHERE DOES THE NOISE COME FROM? (circle the area of the vehicle)

The illustrations are for reference only, and may not reflect the actual configuration of your vehicle.

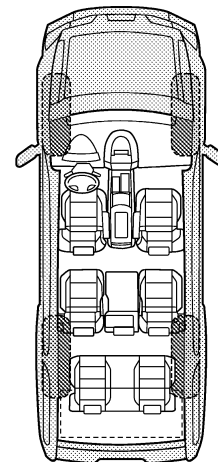
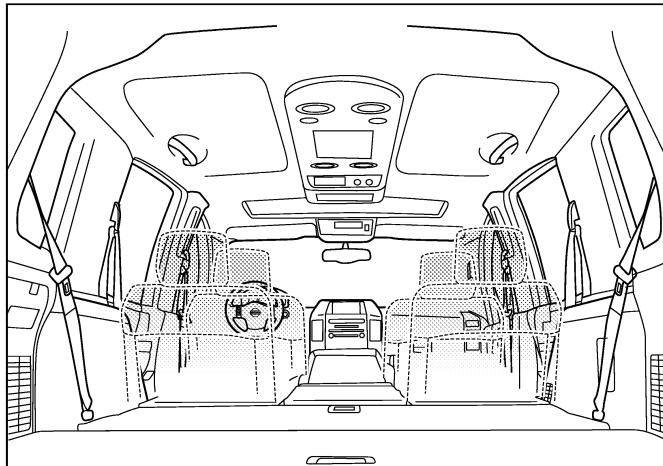
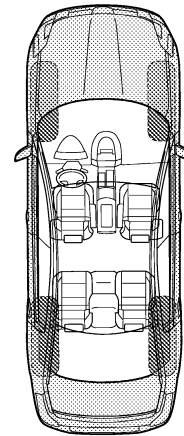
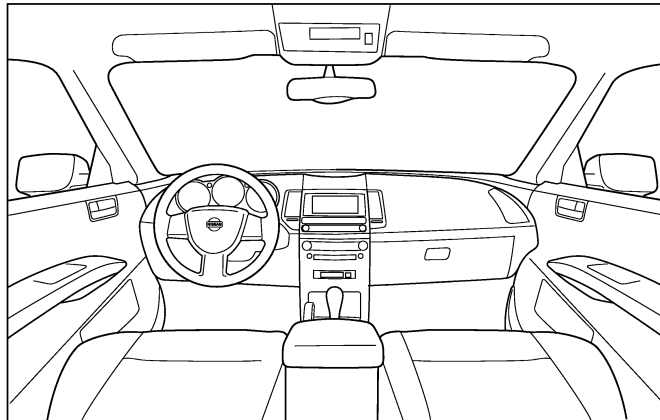

Continue to page 2 of the worksheet and briefly describe the location of the noise or rattle. In addition, please indicate the conditions which are present when the noise occurs.

PIIB8740E

SQUEAK AND RATTLE TROUBLE DIAGNOSES

< SYMPTOM DIAGNOSIS >

[REGULAR GRADE]

SQUEAK & RATTLE DIAGNOSTIC WORKSHEET - page 2

Briefly describe the location where the noise occurs:

II. WHEN DOES IT OCCUR? (please check the boxes that apply)

- | | |
|---|--|
| <input type="checkbox"/> anytime | <input type="checkbox"/> after sitting out in the rain |
| <input type="checkbox"/> 1st time in the morning | <input type="checkbox"/> when it is raining or wet |
| <input type="checkbox"/> only when it is cold outside | <input type="checkbox"/> dry or dusty conditions |
| <input type="checkbox"/> only when it is hot outside | <input type="checkbox"/> other: |

III. WHEN DRIVING:

- through driveways
- over rough roads
- over speed bumps
- only about ____ mph
- on acceleration
- coming to a stop
- on turns: left, right or either (circle)
- with passengers or cargo
- other: _____
- after driving ____ miles or ____ minutes

IV. WHAT TYPE OF NOISE

- squeak (like tennis shoes on a clean floor)
- creak (like walking on an old wooden floor)
- rattle (like shaking a baby rattle)
- knock (like a knock at the door)
- tick (like a clock second hand)
- thump (heavy, muffled knock noise)
- buzz (like a bumble bee)

TO BE COMPLETED BY DEALERSHIP PERSONNEL

Test Drive Notes:

	YES	NO	Initials of person performing
Vehicle test driven with customer	<input type="checkbox"/>	<input type="checkbox"/>	_____
- Noise verified on test drive	<input type="checkbox"/>	<input type="checkbox"/>	_____
- Noise source located and repaired	<input type="checkbox"/>	<input type="checkbox"/>	_____
- Follow up test drive performed to confirm repair	<input type="checkbox"/>	<input type="checkbox"/>	_____

VIN: _____ Customer Name: _____
W.O.# _____ Date: _____

This form must be attached to Work Order

PIIB8742E

A
B
C
D
E
F
G
H
I
SE
K
L
M
N
O
P

PRECAUTION

PRECAUTIONS

Precaution for Supplemental Restraint System (SRS) "AIR BAG" and "SEAT BELT PRE-TENSIONER"

INFOID:000000005492377

The Supplemental Restraint System such as "AIR BAG" and "SEAT BELT PRE-TENSIONER", used along with a front seat belt, helps to reduce the risk or severity of injury to the driver and front passenger for certain types of collision. This system includes seat belt switch inputs and dual stage front air bag modules. The SRS system uses the seat belt switches to determine the front air bag deployment, and may only deploy one front air bag, depending on the severity of a collision and whether the front occupants are belted or unbelted. Information necessary to service the system safely is included in the "SRS AIR BAG" and "SEAT BELT" of this Service Manual.

WARNING:

- To avoid rendering the SRS inoperative, which could increase the risk of personal injury or death in the event of a collision which would result in air bag inflation, all maintenance must be performed by an authorized NISSAN/INFINITI dealer.
- Improper maintenance, including incorrect removal and installation of the SRS, can lead to personal injury caused by unintentional activation of the system. For removal of Spiral Cable and Air Bag Module, see the "SRS AIR BAG".
- Do not use electrical test equipment on any circuit related to the SRS unless instructed to in this Service Manual. SRS wiring harnesses can be identified by yellow and/or orange harnesses or harness connectors.

PRECAUTIONS WHEN USING POWER TOOLS (AIR OR ELECTRIC) AND HAMMERS

WARNING:

- When working near the Air Bag Diagnosis Sensor Unit or other Air Bag System sensors with the ignition ON or engine running, DO NOT use air or electric power tools or strike near the sensor(s) with a hammer. Heavy vibration could activate the sensor(s) and deploy the air bag(s), possibly causing serious injury.
- When using air or electric power tools or hammers, always switch the ignition OFF, disconnect the battery, and wait at least 3 minutes before performing any service.

Service Notice

INFOID:000000005492378

- When removing or installing various parts, place a cloth or padding onto the vehicle body to prevent scratches.
- Handle trim, molding, instruments, grille, etc. carefully during removing or installing. Be careful not to oil or damage them.
- Apply sealing compound where necessary when installing parts.
- When applying sealing compound, be careful that the sealing compound does not protrude from parts.
- When replacing any metal parts (for example body outer panel, members, etc.), be sure to take rust prevention measures.

Precaution for Work

INFOID:000000005492379

- When removing or disassembling each component, be careful not to damage or deform it. If a component may be subject to interference, be sure to protect it with a shop cloth.
- When removing (disengaging) components with a screwdriver or similar tool, be sure to wrap the component with a shop cloth or vinyl tape to protect it.
- Protect the removed parts with a shop cloth and keep them.
- Replace a deformed or damaged clip.
- If a part is specified as a non-reusable part, always replace it with new one.
- Be sure to tighten bolts and nuts securely to the specified torque.
- After re-installation is completed, be sure to check that each part works normally.
- Follow the steps below to clean components.
 - Water soluble foul: Dip a soft cloth into lukewarm water, and wring the water out of the cloth to wipe the fouled area.
 - Then rub with a soft and dry cloth.

PRECAUTIONS

< PRECAUTION >

[REGULAR GRADE]

- Oily foul: Dip a soft cloth into lukewarm water with mild detergent (concentration: within 2 to 3%), and wipe the fouled area.
Then dip a cloth into fresh water, and wring the water out of the cloth to wipe the detergent off. Then rub with a soft and dry cloth.
- Never use organic solvent such as thinner, benzene, alcohol, and gasoline.
- For genuine leather seats, use a genuine leather seat cleaner.

A

B

C

D

E

F

G

H

I

SE

K

L

M

N

O

P

PREPARATION

< PREPARATION >

[REGULAR GRADE]

PREPARATION

PREPARATION

Special Service Tool

INFOID:000000005492380

The actual shapes of Kent-Moore tools may differ from those of special service tools illustrated here.

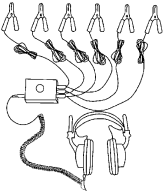
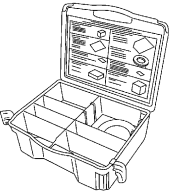
Tool number (Kent-Moore No.) Tool name	Description
<p>(J39570) Chassis ear</p>  <p style="text-align: right;">SIIA0993E</p>	<p>Locates the noise</p>
<p>(J43980) NISSAN Squeak and Rattle Kit</p>  <p style="text-align: right;">SIIA0994E</p>	<p>Repairs the cause of noise</p>

Commercial Service Tool

INFOID:000000005492381

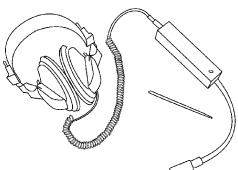
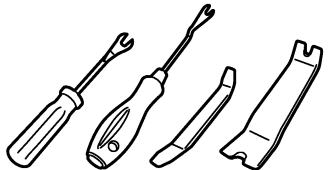
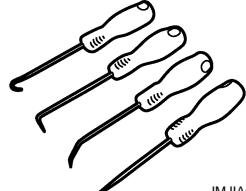
Tool name	Description
<p>Engine ear</p>  <p style="text-align: right;">SIIA0995E</p>	<p>Locates the noise</p>
<p>Remover tool</p>  <p style="text-align: right;">JMKIA3050ZZ</p>	<p>Removes the clips, pawls and metal clips</p>
<p>Hook and pick tool</p>  <p style="text-align: right;">JMJIJA0490ZZ</p>	<p>Removes the snap pins</p>

FRONT SEAT

< REMOVAL AND INSTALLATION >

[REGULAR GRADE]

REMOVAL AND INSTALLATION

FRONT SEAT

Exploded View

INFOID:000000005492382

DRIVER'S SEAT

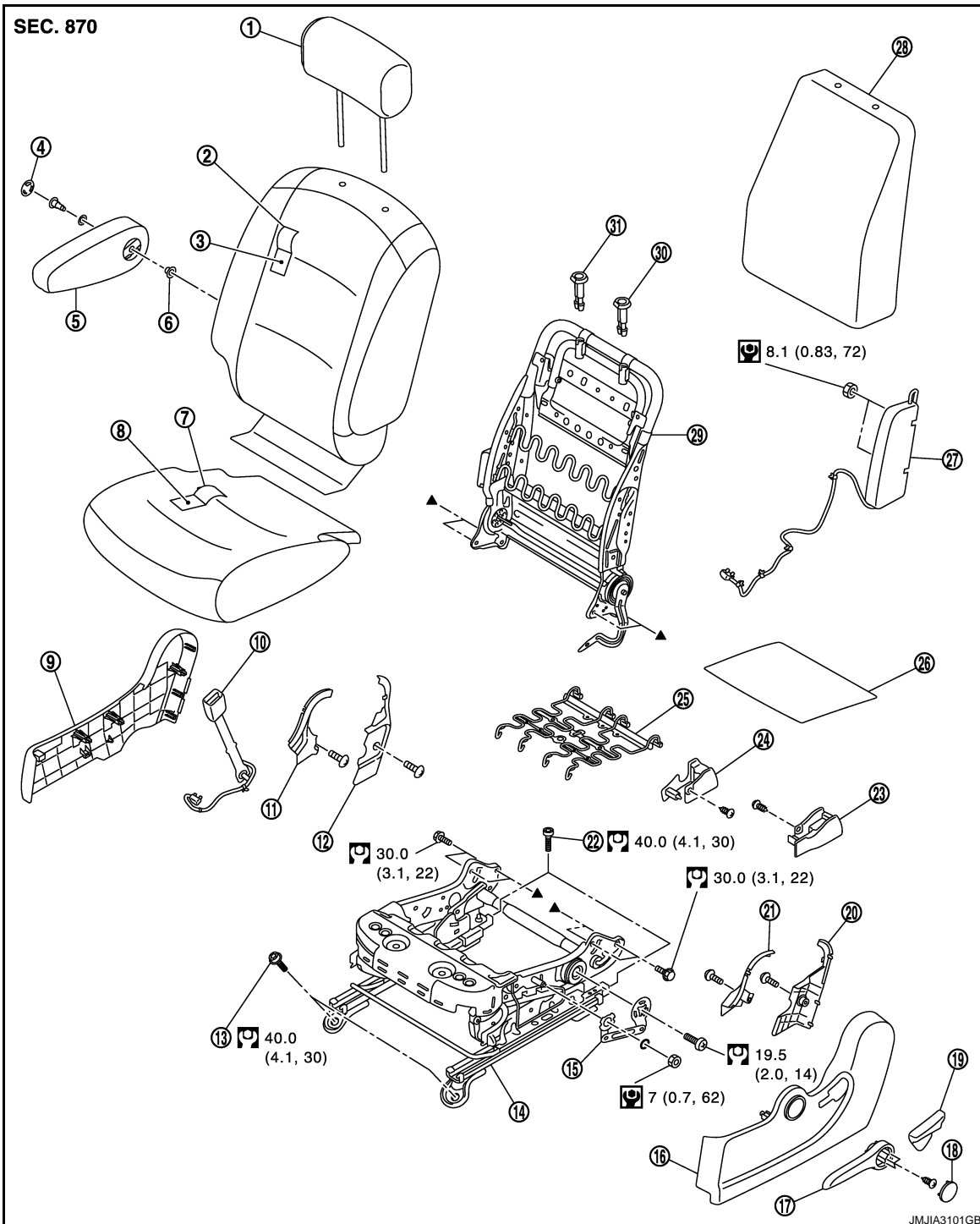

- | | | |
|----------------------|--|---|
| 1. Head rest | 2. Seatback trim | 3. Seatback pad |
| 4. Armrest cap | 5. Armrest assembly | 6. Bush |
| 7. Seat cushion trim | 8. Seat cushion pad | 9. Seat cushion inner finisher |
| 10. Seat belt buckle | 11. Reclining device inner cover (front) | 12. Reclining device inner cover (rear) |

FRONT SEAT

< REMOVAL AND INSTALLATION >

[REGULAR GRADE]

- | | | |
|---------------------------------|---|--|
| 13. TORX bolt | 14. Seat cushion frame | 15. Lifter link |
| 16. Seat cushion outer finisher | 17. Lifter lever knob | 18. Lifter lever knob cap |
| 19. Reclining lever knob | 20. Reclining device outer cover (rear) | 21. Reclining device outer cover (front) |
| 22. TORX bolt | 23. Seat slid outer cover | 24. Seat slid inner cover |
| 25. Seat cushion mat | 26. Seat cushion silencer | 27. Side air bag module |
| 28. Seatback silencer | 29. Seatback frame | 30. Headrest holder (locked) |
| 31. Headrest holder (free) | | |

Refer to [GI-4. "Components"](#) for symbols in the figure.

PASSENGER'S SEAT

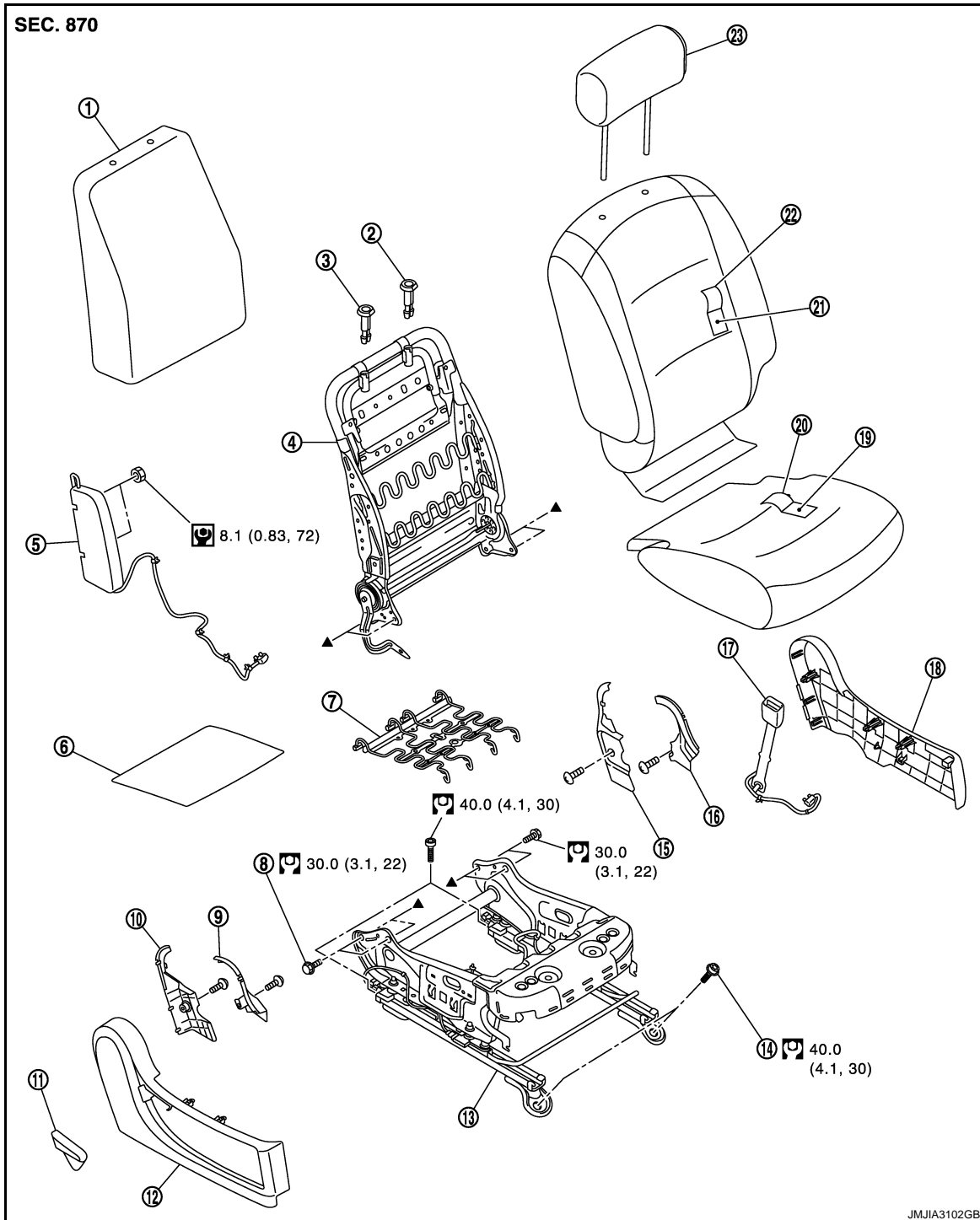

FRONT SEAT

< REMOVAL AND INSTALLATION >

[REGULAR GRADE]

- | | | |
|--|-----------------------------|---|
| 1. Seatback silencer | 2. Headrest holder (locked) | 3. Headrest holder (free) |
| 4. Seatback frame | 5. Side air bag module | 6. Seat cushion silencer |
| 7. Seat cushion | 8. TORX bolt | 9. Reclining device outer cover (front) |
| 10. Reclining device outer cover (rear) | 11. Reclining lever knob | 12. Seat cushion outer finisher |
| 13. Seat cushion frame | 14. TORX bolt | 15. Reclining device inner cover (rear) |
| 16. Reclining device inner cover (front) | 17. Seat belt buckle | 18. Seat cushion inner finisher |
| 19. Seat cushion pad | 20. Seat cushion trim | 21. Seatback pad |
| 22. Seatback trim | 23. Headrest | |

Refer to [GI-4, "Components"](#) for symbols in the figure.

Removal and Installation

INFOID:000000005492383

REMOVAL

CAUTION:

When removing and installing, use shop cloths to protect parts from damage.

1. Remove the headrest.
2. Remove the mounting bolts on the front side of the front seat.
3. Remove the mounting bolts on the rear side of the front seat.
4. Set seatback in a standing position.
5. Disconnect harness connector under the seat and remove harness securing clips.

CAUTION:

Before removal, turn ignition switch OFF, disconnect battery negative terminal and then wait for at least 3 minutes.

6. Remove seat from the vehicle.

CAUTION:

- **When removing and installing, use shop cloths to protect parts from damage.**
- **When removing and installing, 2 workers are required so as to prevent it from dropping.**

INSTALLATION

Install in the reverse order of removal.

CAUTION:

• **Before installation, turn ignition switch OFF, disconnect battery negative terminal and then wait for at least 3 minutes.**

• **Clamp the harness in position.**

NOTE:

After installing the passenger seat, perform zero point reset. Refer to [SRC-8, "ZERO POINT RESET : Description"](#).

Disassembly and Assembly

INFOID:000000005492384

DISASSEMBLY

1. Remove the armrest assembly.
 - Remove the armrest cap.
 - Remove the mounting bolt, and then remove armrest assembly.
2. Remove the seatback trim and seatback pad.
 - Remove the seatback retainer (1), and then open the fastener (2).

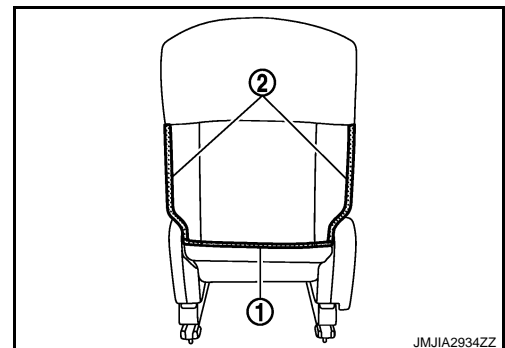

FRONT SEAT

< REMOVAL AND INSTALLATION >

[REGULAR GRADE]

- Remove the seatback retainer from seatback inside.
- Remove the headrest holder.

CAUTION:

**Before installing headrest holder check its orientation.
(front/rear and right/left)**

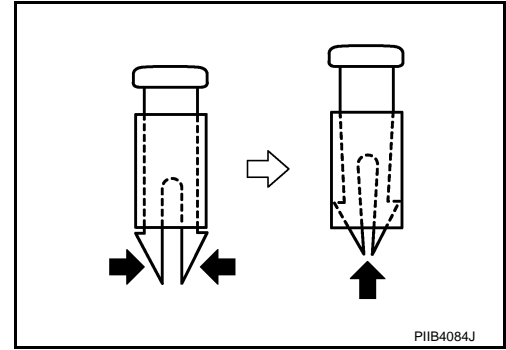

- Remove the side air bag module mounting nuts.
- Remove the seatback trim and seatback pad from the seatback frame.
- Remove the hog rings, and separate the seatback trim and seatback pad.

3. Remove the seatback silencer.

4. Remove the seat cushion outer finisher.

- Remove the pawls, and then lifter lever knob finisher (1).
(Driver's seat only)

 : Pawl

- Remove the mounting screws, and remove the lifter lever (2).
(Driver's seat only)

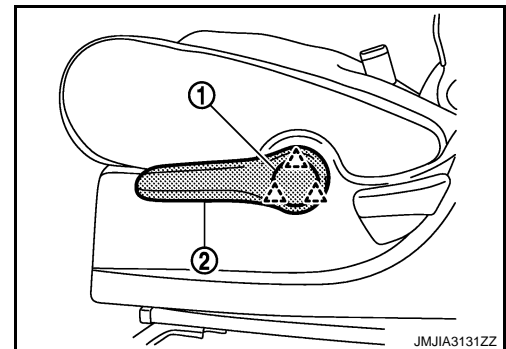

- Pull out the reclining lever while holding and raising the pawl.

 : Pawl

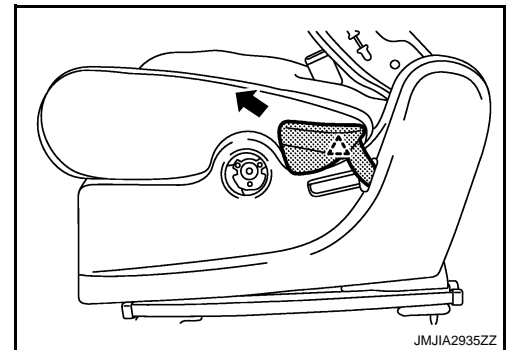

- Remove the metal clip and pawls, and then pull out seat cushion outer finisher outside.

 : Metal clip

 : Pawl

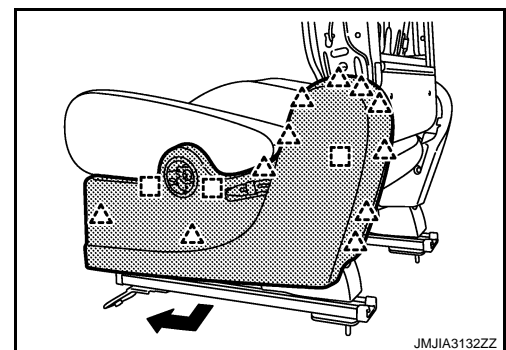

FRONT SEAT

< REMOVAL AND INSTALLATION >

[REGULAR GRADE]

5. Remove the metal clip and pawls, and then pull out seat cushion inner finisher.

- : Metal clip
△ : Pawl

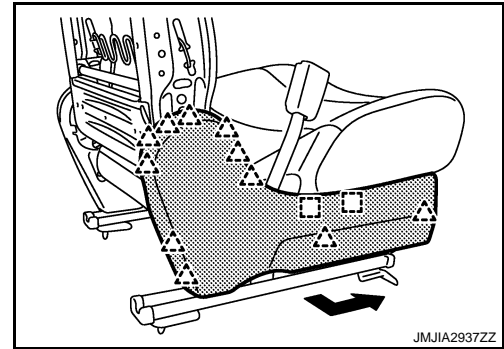

6. Remove the seat belt buckle. Refer to [SB-8, "SEAT BELT BUCKLE : Removal and Installation"](#).
7. Remove the seat cushion trim and seat cushion pad.
- Remove the seat cushion trim retainer.
 - Remove the seat cushion trim and seat cushion pad from the seat cushion frame.
 - Remove the hog rings, and separate the seat cushion trim and seat cushion pad.
8. Remove the seat cushion silencer.
9. Remove the reclining device cover.
- Remove the screws, and then reclining device outer cover (front, rear).
 - Remove the screws, and then reclining device inner cover (front, rear).
10. Remove the mounting bolt, and then remove seatback frame.
11. Remove the seat cushion mat.

Assembly

Assemble in the reverse order of disassembly.

CAUTION:

Install the hog rings of seat trim in position, and then securely connect the trim or trim cord with the pad side wire.

A
B
C
D
E
F
G
H
I
K
L
M
N
O
P

SE

REAR SEAT

< REMOVAL AND INSTALLATION >

[REGULAR GRADE]

REAR SEAT

Exploded View

INFOID:000000005492385

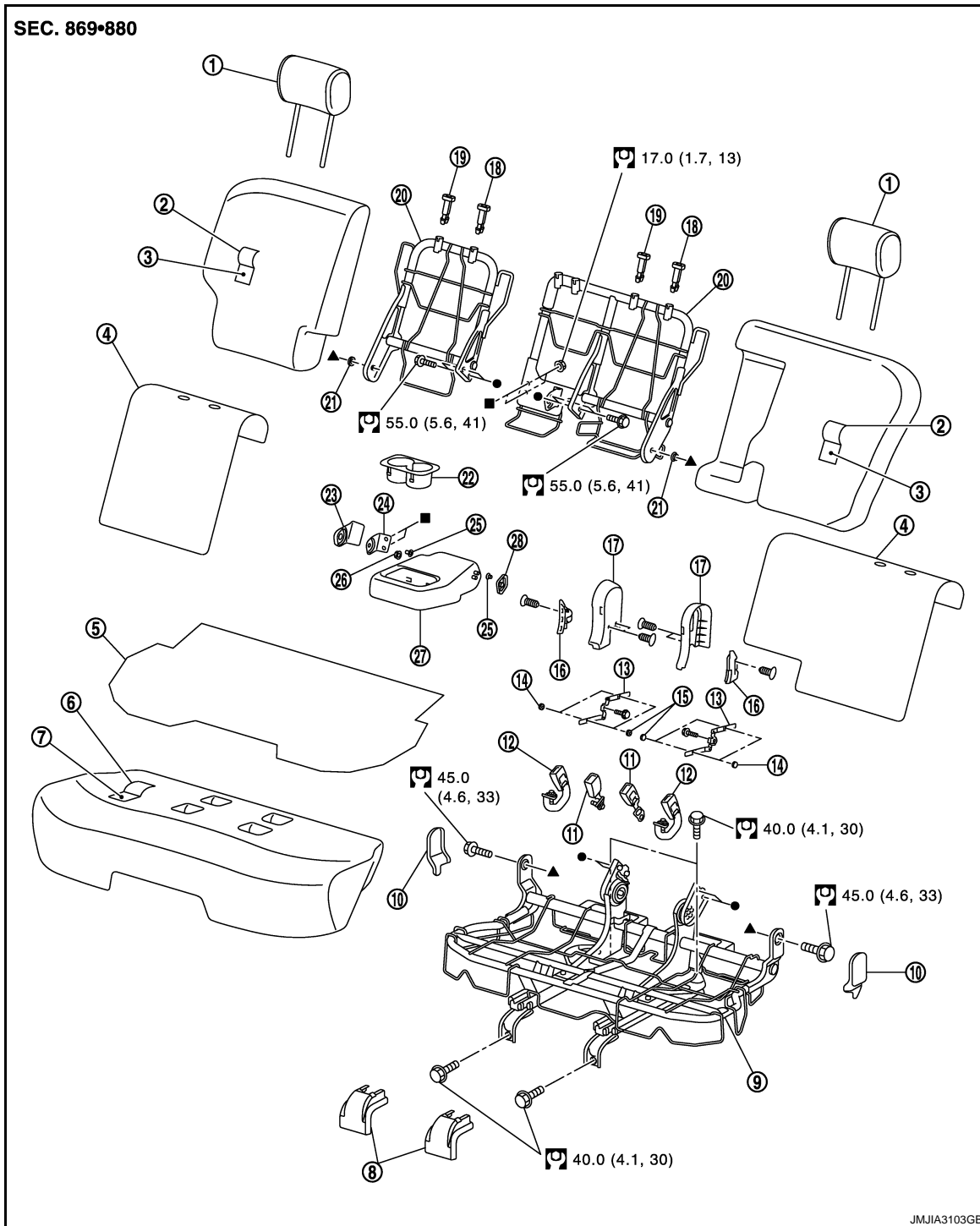

- | | | |
|----------------------------|-----------------------------|-------------------------------|
| 1. Headrest | 2. Seatback trim | 3. Seatback pad |
| 4. Seatback silencer | 5. Seat cushion silencer | 6. Seat cushion trim |
| 7. Seat cushion pad | 8. Seat slide cover | 9. Seat cushion frame |
| 10. Outer hinge finisher | 11. Seat belt buckle (side) | 12. Seat belt buckle (center) |
| 13. Reclining strap | 14. Rivet A | 15. Rivet B |
| 16. Inner finisher | 17. Reclining device cover | 18. Headrest holder (locked) |
| 19. Headrest holder (free) | 20. Seatback frame | 21. Seatback bush |

REAR SEAT

< REMOVAL AND INSTALLATION >

[REGULAR GRADE]

- | | | |
|------------------------------|----------------------------|---------------------------|
| 22. Cup holder | 23. Armrest hinge finisher | 24. Armrest hinge bracket |
| 25. Armrest hinge bush B | 26. Armrest hinge bush A | 27. Armrest assembly |
| 28. Armrest hinge inner bush | | |
- Refer to [GI-4, "Components"](#) for symbols in the figure.

Removal and Installation

INFOID:000000005492386

REMOVAL

CAUTION:

When removing and installing, use shop cloths to protect parts from damage.

1. Remove the headrest.
2. Remove the pawls, and then remove seat slide cover.

 : Pawl

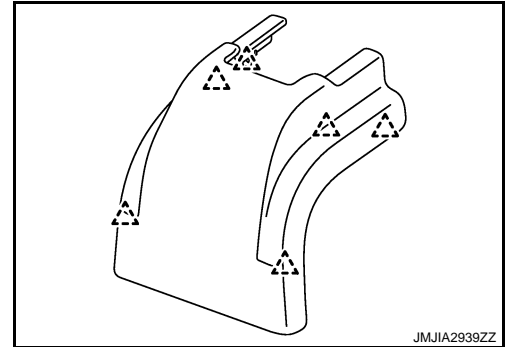

3. Remove the rear right side mounting bolt.
4. Remove the rear left side mounting bolt.
5. Remove the front right side mounting bolt.
6. Remove the front left side mounting bolt.
7. Remove the rear seat assembly from back door.

INSTALLATION

Install in the reverse order of removal.

CAUTION:

When removing and installing, use shop cloths to protect parts from damage.

Disassembly and Assembly

INFOID:000000005492387

SEATBACK

Disassembly

1. Remove the armrest assembly.
 - Remove the seatback retainers (1), and then open the fasteners (2).

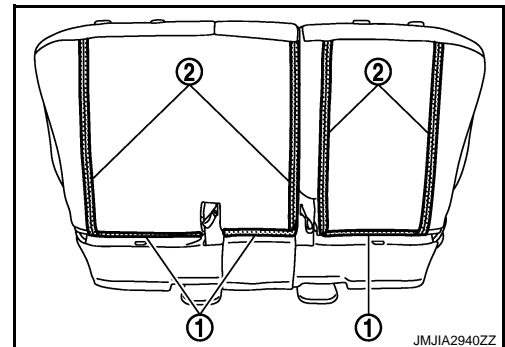

- Remove the armrest hinge bracket mounting nuts.

A
B
C
D
E
F
G
H
I
SE
K
L
M
N
O
P

REAR SEAT

< REMOVAL AND INSTALLATION >

[REGULAR GRADE]

- Remove the pawl of armrest hinge inner bush, and then slide armrest assembly.

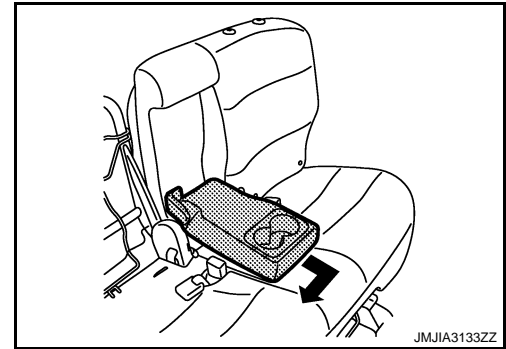

2. Remove the seatback trim and seatback pad.
 - Remove the seatback retainers (1), and then open the fasteners (2).

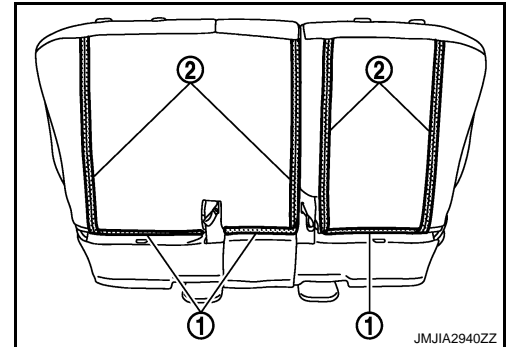

- Remove the headrest holder.
CAUTION:
Before installing headrest holder check its orientation.
(front/rear and right/left)

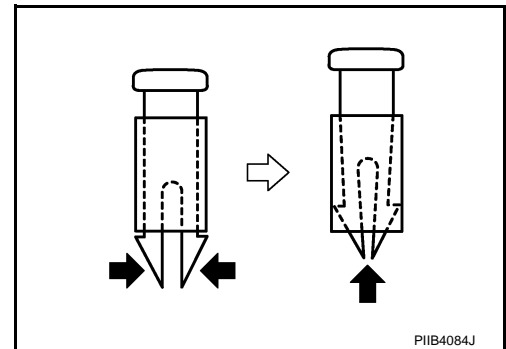

- Remove the seatback trim and seatback pad from seatback frame.
 - Remove the hog rings to separate the seatback trim and seatback pad.
3. Remove the seatback silencer.
 4. Remove the seatback frame.
 - Remove the pawls, and then remove outer hinge finisher.

 : Pawl

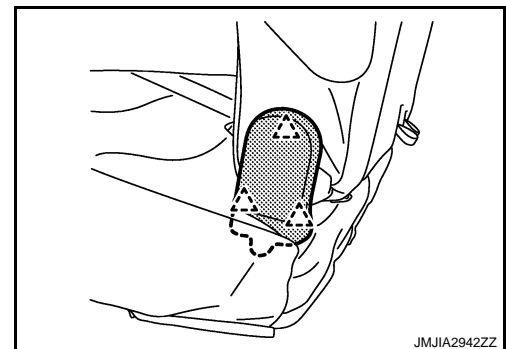

- Remove the mounting bolts (inside, outside), and then remove seatback frame.

Assembly
Assemble in the reverse order of disassembly.

CAUTION:

REAR SEAT

< REMOVAL AND INSTALLATION >

[REGULAR GRADE]

Install the hog rings of seatback trim in position, and then securely connect the trim or trim cord with the seatback frame.

SEAT CUSHION

Disassembly

1. Remove the seatback assembly.
 - Remove the seatback retainers (1), and then open the fasteners (2).

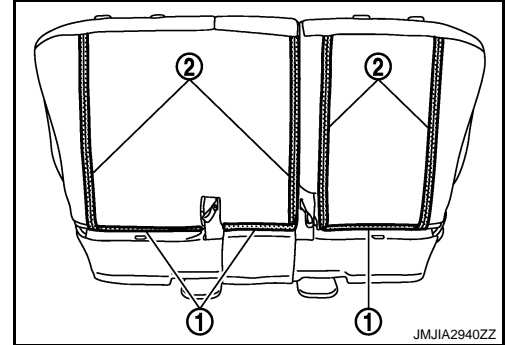

- Remove the pawls, and then remove outer hinge finisher.

 : Pawl

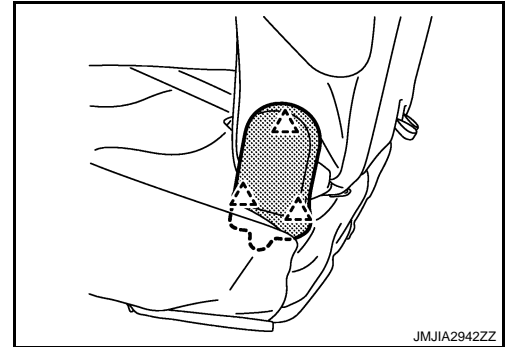

2. Remove the seat cushion trim and seat cushion pad.
 - Remove the mounting bolts (inside, outside), and then remove seatback frame.
 - Remove the seat cushion retainers from seat cushion back side.

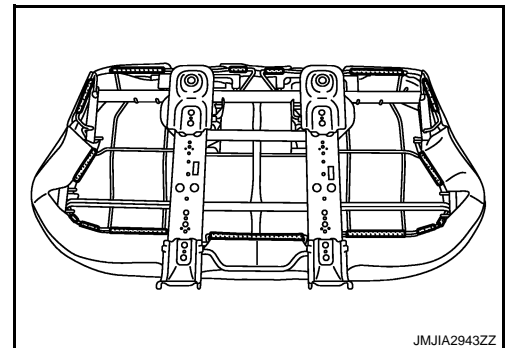

- Remove the seat cushion trim and seat cushion pad from seat cushion frame.
 - Remove the hog rings to separate the seat cushion trim and seat cushion pad.
3. Remove the seat cushion silencer.
 4. Remove the seat belt buckle. Refer to [SB-13, "SEAT BELT BUCKLE : Removal and Installation"](#).

REAR SEAT

< REMOVAL AND INSTALLATION >

[REGULAR GRADE]

5. Remove the clip and pawls, and then remove inner finisher.

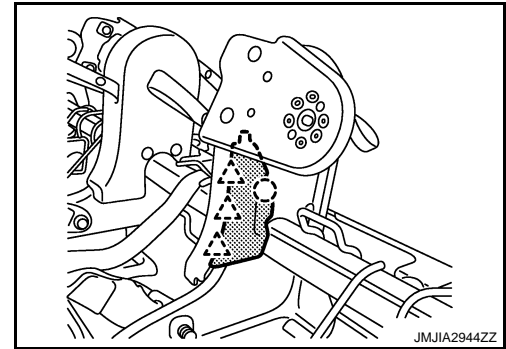
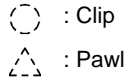

6. Remove the reclining device cover.
 - Remove the clip.
 - Remove the reclining strap mounting bolt.

CAUTION:

Perform it after seatback folded state.

Assembly

Assemble in the reverse order of disassembly.

CAUTION:

Install the hog rings of seat cushion trim in position, and then securely connect the trim or trim cord with the seat cushion pad wire.

ARMREST ASSEMBLY

Disassembly

1. Remove the pawls, and then remove cup holder.

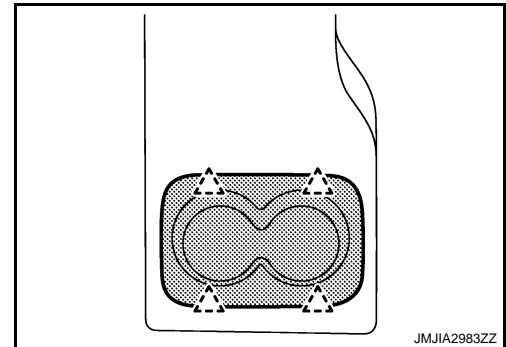
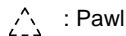

2. Remove the armrest inner hinge bush.
3. Remove the hinge bracket.
 - Remove the pawl of armrest hinge bush, and then remove armrest hinge bracket from armrest assembly.
 - Remove the armrest hinge finisher from armrest hinge bracket.

Assembly

Assemble in the reverse order of disassembly.

< SPEC CHANGE INFORMATION >

SPEC CHANGE INFORMATION

SEAT

Seat

- The seats use special cloth.

INFOID:000000005492388

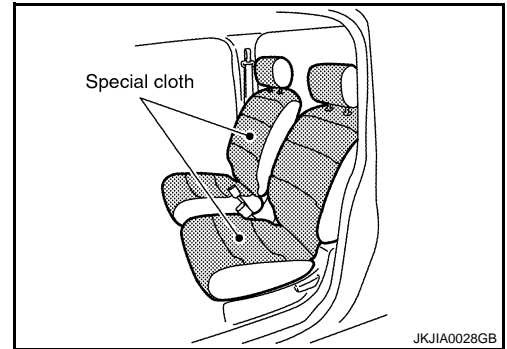

A
B
C
D
E
F
G
H
I
SE
K
L
M
N
O
P

SE