

A
CO
C
D
E
F
G
H
I
J
K
L
M
N
O
P

SECTION CO

ENGINE COOLING SYSTEM

CONTENTS

<p>SYSTEM DESCRIPTION 2</p> <p>DESCRIPTION 2</p> <p style="padding-left: 20px;">Engine Cooling System2</p> <p style="padding-left: 20px;">Engine Cooling System Schematic3</p> <p>SYMPTOM DIAGNOSIS 4</p> <p>OVERHEATING CAUSE ANALYSIS 4</p> <p style="padding-left: 20px;">Troubleshooting Chart4</p> <p>PRECAUTION 6</p> <p>PRECAUTIONS 6</p> <p style="padding-left: 20px;">Precaution for Supplemental Restraint System (SRS) "AIR BAG" and "SEAT BELT PRE-TENSIONER"6</p> <p style="padding-left: 20px;">Precaution Necessary for Steering Wheel Rotation after Battery Disconnect6</p> <p>PREPARATION 8</p> <p>PREPARATION 8</p> <p style="padding-left: 20px;">Commercial Service Tools8</p> <p>PERIODIC MAINTENANCE 9</p> <p>ENGINE COOLANT 9</p> <p style="padding-left: 20px;">Inspection9</p> <p style="padding-left: 20px;">Draining9</p> <p style="padding-left: 20px;">Refilling10</p> <p style="padding-left: 20px;">Flushing11</p> <p>RADIATOR12</p> <p>RADIATOR CAP12</p> <p style="padding-left: 20px;">RADIATOR CAP : Inspection12</p> <p>RADIATOR12</p> <p style="padding-left: 20px;">RADIATOR : Inspection12</p>	<p>REMOVAL AND INSTALLATION14</p> <p>RADIATOR14</p> <p style="padding-left: 20px;">Exploded View14</p> <p style="padding-left: 20px;">Removal and Installation14</p> <p style="padding-left: 20px;">Inspection15</p> <p>COOLING FAN16</p> <p style="padding-left: 20px;">Exploded View16</p> <p style="padding-left: 20px;">Removal and Installation16</p> <p style="padding-left: 20px;">Disassembly and Assembly17</p> <p style="padding-left: 20px;">Inspection17</p> <p>WATER PUMP18</p> <p style="padding-left: 20px;">Exploded View18</p> <p style="padding-left: 20px;">Removal and Installation18</p> <p style="padding-left: 20px;">Inspection18</p> <p>THERMOSTAT20</p> <p style="padding-left: 20px;">Exploded View20</p> <p style="padding-left: 20px;">Removal and Installation20</p> <p style="padding-left: 20px;">Inspection21</p> <p>WATER OUTLET22</p> <p style="padding-left: 20px;">Exploded View22</p> <p style="padding-left: 20px;">Removal and Installation22</p> <p style="padding-left: 20px;">Inspection23</p> <p>SERVICE DATA AND SPECIFICATIONS (SDS)24</p> <p>SERVICE DATA AND SPECIFICATIONS (SDS)24</p> <p style="padding-left: 20px;">Periodical Maintenance Specification24</p> <p style="padding-left: 20px;">Radiator24</p> <p style="padding-left: 20px;">Thermostat24</p> <p style="padding-left: 20px;">Water Control Valve24</p>
--	--

DESCRIPTION

< SYSTEM DESCRIPTION >

SYSTEM DESCRIPTION

DESCRIPTION

Engine Cooling System

INFOID:000000005491473

M/T models

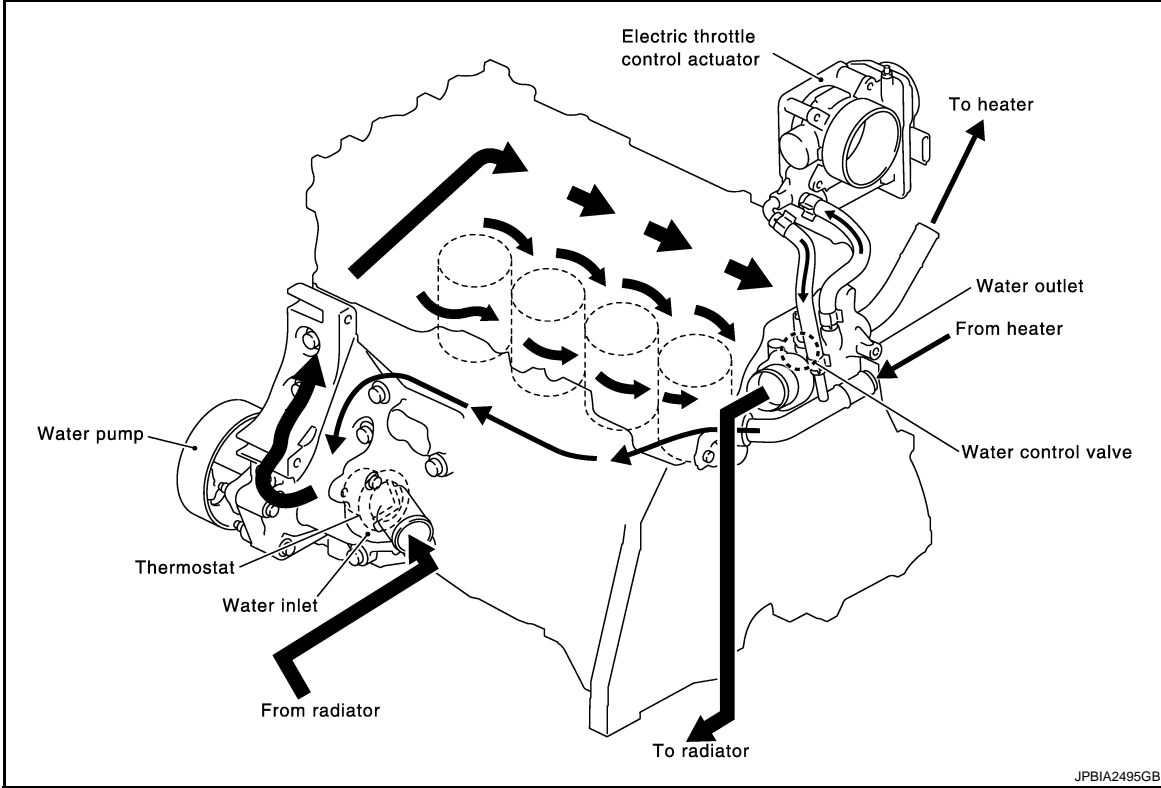

CVT models

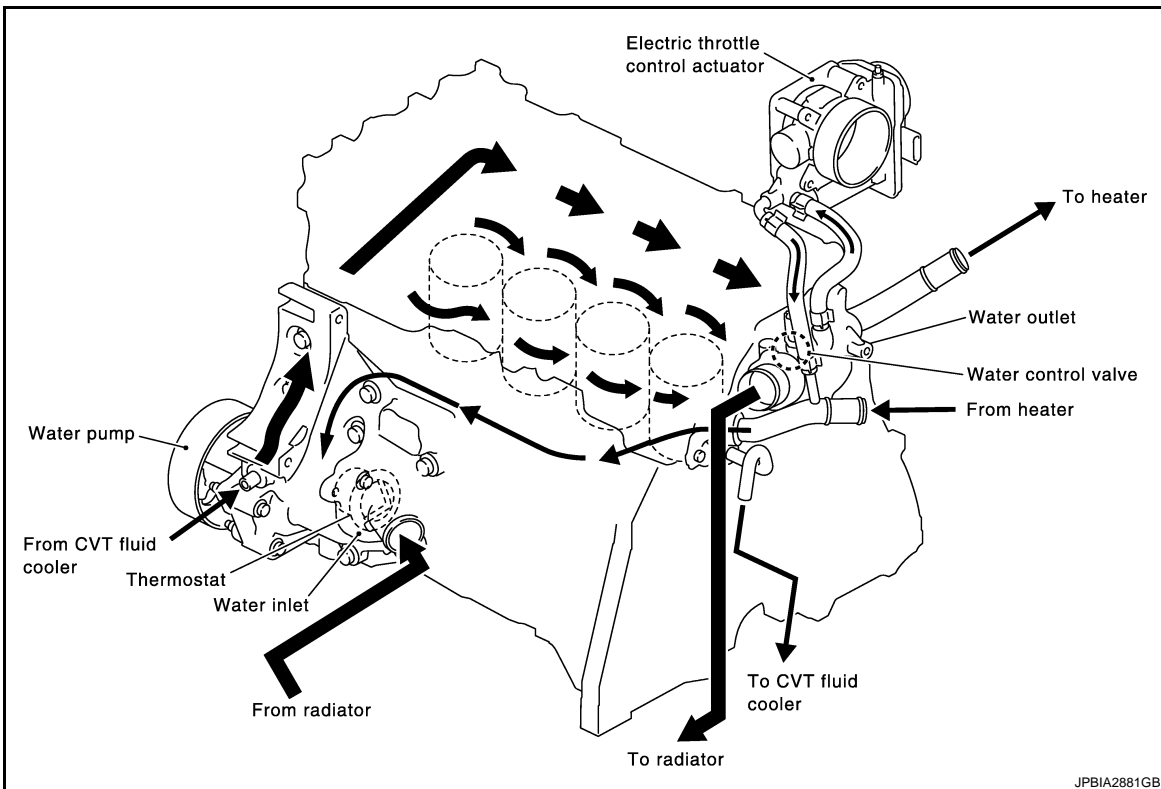

DESCRIPTION

< SYSTEM DESCRIPTION >

Engine Cooling System Schematic

INFOID:000000005491474

A

CO

C

D

E

F

G

H

I

J

K

L

M

N

O

P

M/T models

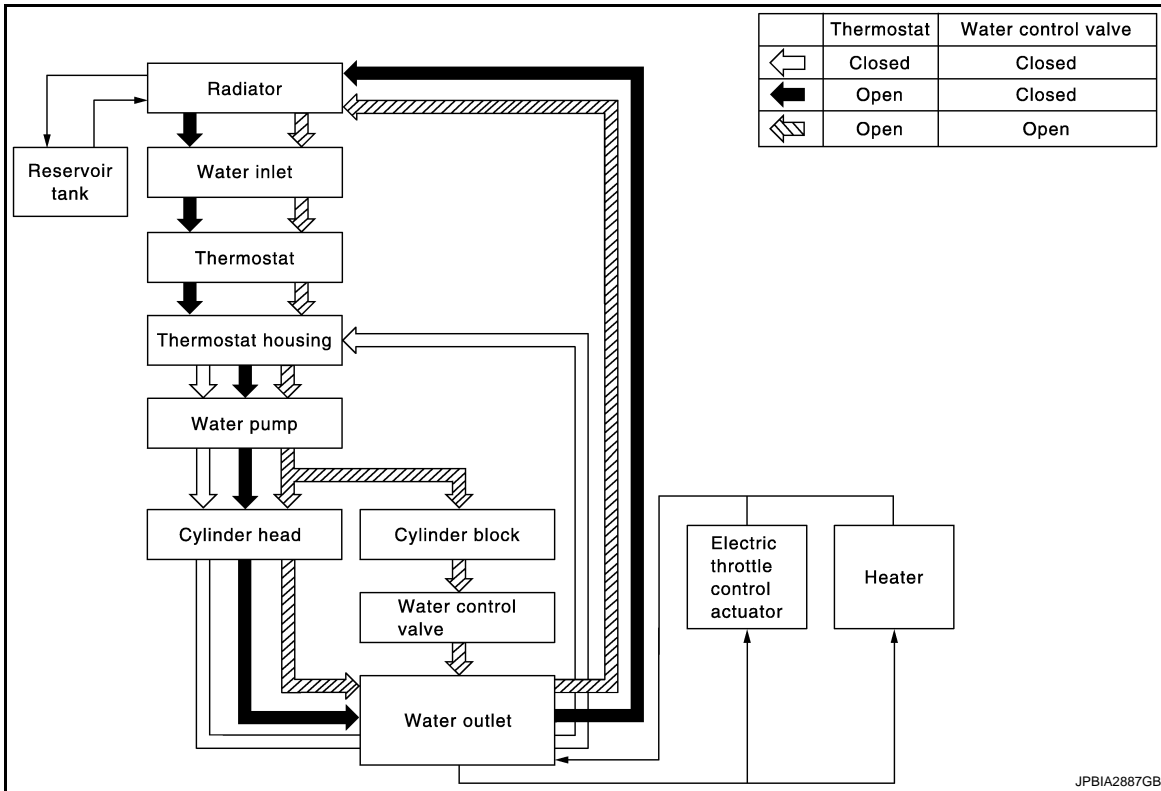

CVT models

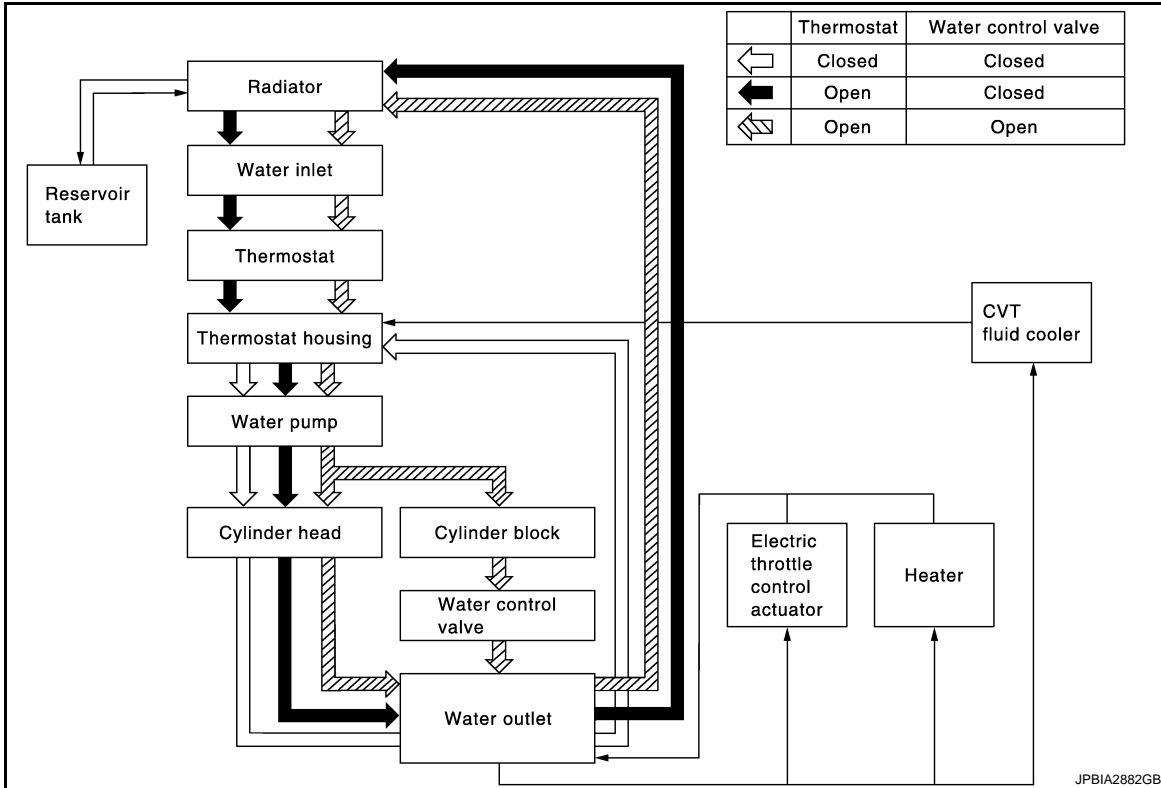

OVERHEATING CAUSE ANALYSIS

< SYMPTOM DIAGNOSIS >

SYMPTOM DIAGNOSIS

OVERHEATING CAUSE ANALYSIS

Troubleshooting Chart

INFOID:000000005491475

		Symptom	Check items		
Cooling system parts malfunction	Poor heat transfer	Water pump malfunction	Worn or loose drive belt	—	
		Thermostat and water control valve stuck closed	—		
		Damaged fins	Dust contamination or paper clogging		
			Physical damage		
		Clogged radiator cooling tube	Excess foreign material (rust, dirt, sand, etc.)		
	Reduced air flow	Cooling fan does not operate	Fan assembly	—	
		High resistance to fan rotation			
		Damaged fan blades			
		Damaged radiator shroud	—	—	
		Improper engine coolant mixture ratio	—	—	
		Poor engine coolant quality	—	Engine coolant viscosity	—
	Insufficient engine coolant	Engine coolant leakage	Cooling hose	Loose clamp	
				Cracked hose	
			Water pump	Poor sealing	
			Radiator cap	Loose	
Poor sealing					
Radiator		O-ring for damage, deterioration or improper fitting			
		Cracked radiator tank			
		Cracked radiator core			
Reservoir tank	Cracked reservoir tank				
Overflowing reservoir tank	Exhaust gas leakage into cooling system	Cylinder head deterioration			
		Cylinder head gasket deterioration			

OVERHEATING CAUSE ANALYSIS

< SYMPTOM DIAGNOSIS >

	Symptom		Check items			
Except cooling system parts malfunction	—	Overload on engine	Abusive driving	High engine rpm under no load	A	
				Driving in low gear for extended time	CO	
				Driving at extremely high speed		
				Power train system malfunction	—	C
			Installed improper size wheels and tires		—	D
			Dragging brakes			
		Blocked or restricted air flow	Blocked bumper	—	E	
			Blocked radiator grille	Installed car brassiere		
				Mud contamination or paper clogging	—	F
			Blocked radiator	—		
			Blocked condenser	Blocked air flow		G
		Installed large fog lamp				

A
CO
C
D
E
F
G
H
I
J
K
L
M
N
O
P

PRECAUTIONS

< PRECAUTION >

PRECAUTION

PRECAUTIONS

Precaution for Supplemental Restraint System (SRS) "AIR BAG" and "SEAT BELT PRE-TENSIONER"

INFOID:000000005491476

The Supplemental Restraint System such as "AIR BAG" and "SEAT BELT PRE-TENSIONER", used along with a front seat belt, helps to reduce the risk or severity of injury to the driver and front passenger for certain types of collision. This system includes seat belt switch inputs and dual stage front air bag modules. The SRS system uses the seat belt switches to determine the front air bag deployment, and may only deploy one front air bag, depending on the severity of a collision and whether the front occupants are belted or unbelted. Information necessary to service the system safely is included in the "SRS AIR BAG" and "SEAT BELT" of this Service Manual.

WARNING:

- To avoid rendering the SRS inoperative, which could increase the risk of personal injury or death in the event of a collision which would result in air bag inflation, all maintenance must be performed by an authorized NISSAN/INFINITI dealer.
- Improper maintenance, including incorrect removal and installation of the SRS, can lead to personal injury caused by unintentional activation of the system. For removal of Spiral Cable and Air Bag Module, see the "SRS AIR BAG".
- Do not use electrical test equipment on any circuit related to the SRS unless instructed to in this Service Manual. SRS wiring harnesses can be identified by yellow and/or orange harnesses or harness connectors.

PRECAUTIONS WHEN USING POWER TOOLS (AIR OR ELECTRIC) AND HAMMERS

WARNING:

- When working near the Air Bag Diagnosis Sensor Unit or other Air Bag System sensors with the ignition ON or engine running, DO NOT use air or electric power tools or strike near the sensor(s) with a hammer. Heavy vibration could activate the sensor(s) and deploy the air bag(s), possibly causing serious injury.
- When using air or electric power tools or hammers, always switch the ignition OFF, disconnect the battery, and wait at least 3 minutes before performing any service.

Precaution Necessary for Steering Wheel Rotation after Battery Disconnect

INFOID:000000005491477

NOTE:

- Before removing and installing any control units, first turn the push-button ignition switch to the LOCK position, then disconnect both battery cables.
- After finishing work, confirm that all control unit connectors are connected properly, then re-connect both battery cables.
- Always use CONSULT-III to perform self-diagnosis as a part of each function inspection after finishing work. If a DTC is detected, perform trouble diagnosis according to self-diagnosis results.

For vehicle with steering lock unit, if the battery is disconnected or discharged, the steering wheel will lock and cannot be turned.

If turning the steering wheel is required with the battery disconnected or discharged, follow the operation procedure below before starting the repair operation.

OPERATION PROCEDURE

1. Connect both battery cables.

NOTE:

Supply power using jumper cables if battery is discharged.

2. Turn the push-button ignition switch to ACC position.
(At this time, the steering lock will be released.)
3. Disconnect both battery cables. The steering lock will remain released with both battery cables disconnected and the steering wheel can be turned.
4. Perform the necessary repair operation.

PRECAUTIONS

< PRECAUTION >

5. When the repair work is completed, re-connect both battery cables. With the brake pedal released, turn the push-button ignition switch from ACC position to ON position, then to LOCK position. (The steering wheel will lock when the push-button ignition switch is turned to LOCK position.)
6. Perform self-diagnosis check of all control units using CONSULT-III.

A

CO

C

D

E

F

G

H

I

J

K

L

M

N

O

P

PREPARATION

< PREPARATION >

PREPARATION

PREPARATION

Commercial Service Tools

INFOID:000000005491478

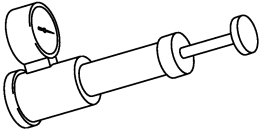
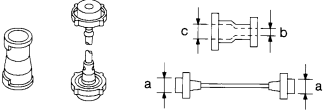
Tool name	Description
<p data-bbox="164 415 354 443">Radiator cap tester</p>  <p data-bbox="850 632 922 646">PBIC1982E</p>	<p data-bbox="1013 415 1360 443">Checking radiator and radiator cap</p>
<p data-bbox="164 665 440 693">Radiator cap tester adapter</p>  <p data-bbox="850 884 922 898">S-NT564</p>	<p data-bbox="1013 665 1442 716">Adapting radiator cap tester to radiator cap and radiator filler neck</p> <p data-bbox="1013 722 1175 749">a: 28 (1.10) dia.</p> <p data-bbox="1013 753 1208 781">b: 31.4 (1.236) dia.</p> <p data-bbox="1013 785 1208 812">c: 41.3 (1.626) dia.</p> <p data-bbox="1013 816 1143 844">Unit: mm (in)</p>

ENGINE COOLANT

< PERIODIC MAINTENANCE >

PERIODIC MAINTENANCE

ENGINE COOLANT

Inspection

INFOID:000000005491479

LEVEL

- Check that the reservoir tank engine coolant level is within the "MIN" to "MAX" when the engine is cool.

A : MAX

B : MIN

- Adjust the engine coolant level if necessary.

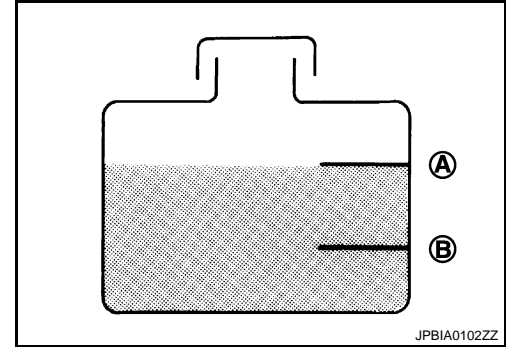

LEAKAGE

- To check for leakage, apply pressure to the cooling system with the radiator cap tester (commercial service tool) (A) and the radiator cap tester adapter (commercial service tool) (B).

Testing pressure: Refer to [CO-24, "Radiator"](#).

WARNING:

Never remove radiator cap when engine is hot. Serious burns may occur from high-pressure engine coolant escaping from radiator.

CAUTION:

Higher test pressure than specified may cause radiator damage.

NOTE:

In a case that engine coolant decreases, replenish radiator with engine coolant.

- If anything is found, repair or replace damaged parts.

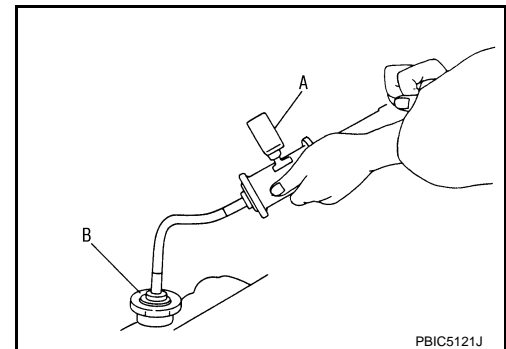

Draining

INFOID:000000005491480

WARNING:

- Never remove radiator cap when engine is hot. Serious burns may occur from high-pressure engine coolant escaping from radiator.
- Wrap a thick cloth around the radiator cap. Slowly turn it a quarter of a turn to release built-up pressure. Then turn it all the way.

1. Remove engine under cover.
2. Open radiator drain plug (A) at the bottom of radiator, and then remove radiator cap.

← : Vehicle front

CAUTION:

Perform this step when engine is cold.

- When draining all of engine coolant in the system, open water drain plugs on cylinder block. Refer to [EM-87, "Disassembly and Assembly"](#).

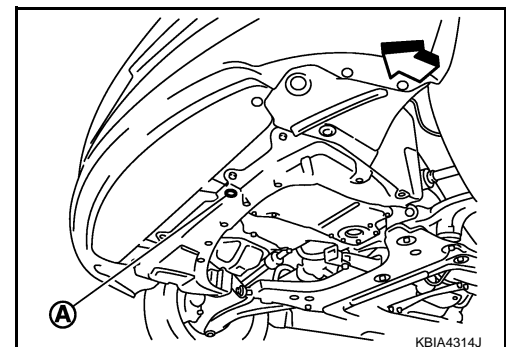

3. Remove reservoir tank if necessary, and drain engine coolant and clean reservoir tank before installing. Refer to [CO-14, "Exploded View"](#).

ENGINE COOLANT

< PERIODIC MAINTENANCE >

4. Check drained engine coolant for contaminants such as rust, corrosion or discoloration. If contaminated, flush the engine cooling system. Refer to [CO-11, "Flushing"](#).

Refilling

INFOID:000000005491481

1. Install reservoir tank if removed and radiator drain plug.

CAUTION:

Be sure to clean drain plug and install with new O-ring.

Radiator drain plug : Refer to [CO-14, "Exploded View"](#).

- If water drain plugs on cylinder block are removed, close and tighten them. Refer to [EM-87, "Disassembly and Assembly"](#).
2. Check that each hose clamp has been firmly tightened.
 3. Remove air duct (between air cleaner case and electric throttle control actuator). Refer to [EM-24, "Exploded View"](#).
 4. Disconnect heater hose (1) at position (◀) in the figure.

◀ : Vehicle front

- Enhance heater hose as high as possible.

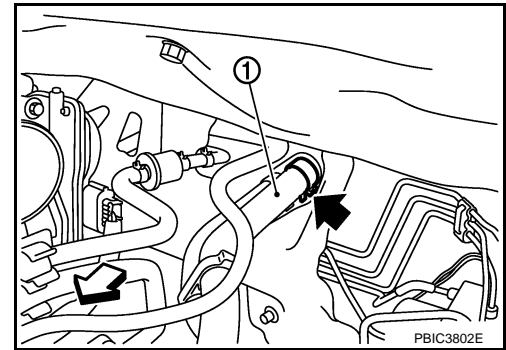

5. Fill radiator (1) to specified level.

CAUTION:

Never adhere the engine coolant to electronic equipments (alternator etc.).

- Pour coolant slowly of less than 2 ℓ (2-1/8 US qt, 1-3/4 Imp qt) a minute to allow air in system to escape.
- When engine coolant overflows disconnected heater hose, connect heater hose, and continue filling the engine coolant.
- Use Genuine NISSAN Long Life Antifreeze/Coolant or equivalent mixed with water (distilled or demineralized). Refer to [MA-10, "Fluids and Lubricants"](#).

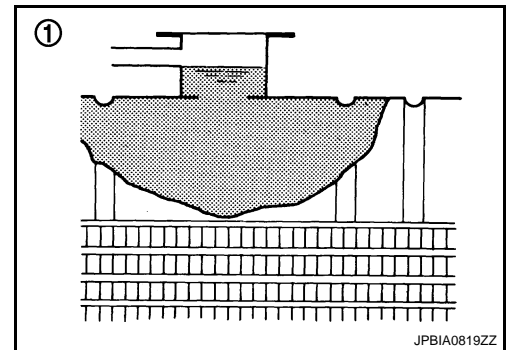

Engine coolant capacity

(With reservoir tank at "MAX" level)

Refer to [CO-24, "Periodical Maintenance Specification"](#).

6. Refill reservoir tank to "MAX" level line with engine coolant.

A : MAX

B : MIN

Reservoir tank engine coolant capacity
(At "MAX" level)

Refer to [CO-24, "Periodical Maintenance Specification"](#).

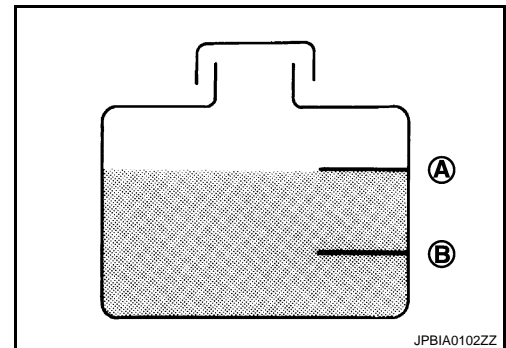

7. Install air duct (between air cleaner case and electric throttle control actuator). Refer to [EM-24, "Exploded View"](#).

ENGINE COOLANT

< PERIODIC MAINTENANCE >

8. Install radiator cap.
9. Warm up engine until opening thermostat. Standard for warming-up time is approximately 10 minutes at 3,000 rpm.
 - Check thermostat opening condition by touching radiator hose (lower) to see a flow of warm water.**CAUTION:**
Watch water temperature gauge so as not to overheat engine.
10. Stop the engine and cool down to less than approximately 50°C (122°F).
 - Cool down using fan to reduce the time.
 - If necessary, refill radiator up to filler neck with engine coolant.**CAUTION:**
Never adhere the engine coolant to electronic equipments (alternator etc.).
11. Refill reservoir tank to "MAX" level line with engine coolant.
12. Repeat steps 5 through 10 two or more times with radiator cap installed until engine coolant level no longer drops.
13. Check cooling system for leakage with engine running.
14. Warm up the engine, and check for sound of engine coolant flow while running engine from idle up to 3,000 rpm with heater temperature controller set at several position between "COOL" and "WARM".
 - Sound may be noticeable at heater unit.
15. Repeat step 14 three times.
16. If sound is heard, bleed air from cooling system by repeating step 5 through 10 until reservoir tank level no longer drops.

Flushing

INFOID:000000005491462

1. Install reservoir tank if removed and radiator drain plug.
CAUTION:
Be sure to clean drain plug and install with new O-ring.

Radiator drain plug : Refer to [CO-14, "Exploded View"](#).

- If water drain plugs on cylinder block are removed, close and tighten them. Refer to [EM-87, "Disassembly and Assembly"](#).
2. Remove air duct (between air cleaner case and electric throttle control actuator). Refer to [EM-24, "Exploded View"](#).
 3. Disconnect heater hose (1) at position (←) in the figure.

← : Vehicle front

- Enhance heater as high as possible.

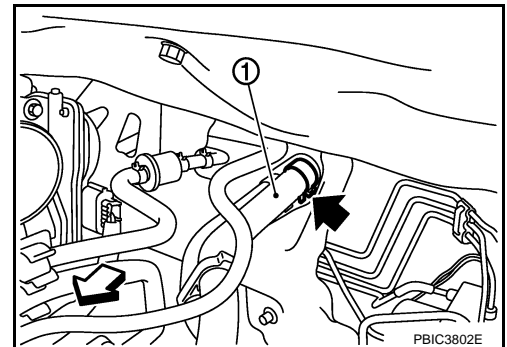

4. Fill radiator and reservoir tank with water and reinstall radiator cap.
 - When engine coolant over flows disconnected heater hose, connect heater hose, and continue filling the engine coolant.
5. Install air duct (between air cleaner case and electric throttle control actuator). Refer to [EM-24, "Exploded View"](#).
6. Run the engine and warm it up to normal operating temperature.
7. Rev the engine two or three times under no-load.
8. Stop the engine and wait until it cools down.
9. Drain water from the system. Refer to [CO-9, "Draining"](#).
10. Repeat steps 1 through 9 until clear water begins to drain from radiator.

RADIATOR

< PERIODIC MAINTENANCE >

RADIATOR

RADIATOR CAP

RADIATOR CAP : Inspection

INFOID:000000005491483

- Check valve seat (A) of radiator cap.

B : Metal plunger

- Check that valve seat is swollen to the extent that the edge of the plunger cannot be seen when watching it vertically from the top.
- Check that valve seat has no soil and damage.

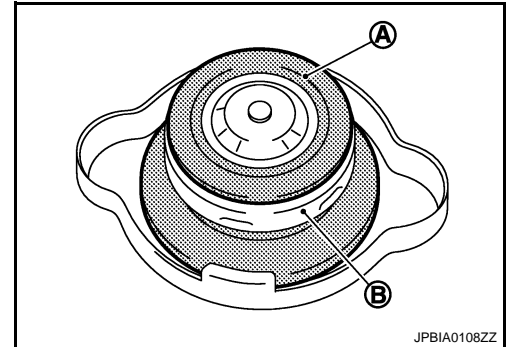

- Pull negative-pressure valve to open it, and that it close completely when released.
- Check that there is no dirt or damage on the valve seat of radiator cap negative-pressure valve.
- Check that there are no unusualness in the opening and closing conditions of negative-pressure valve.

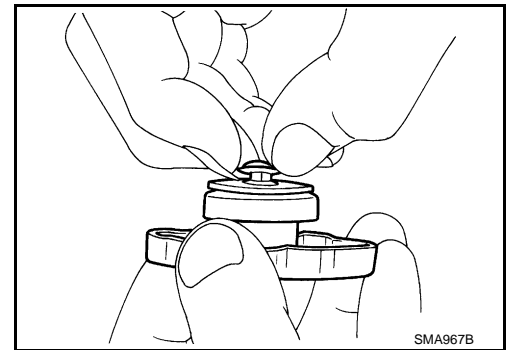

- Check radiator cap relief pressure.

Standard and Limit : Refer to [CO-24, "Radiator"](#).

- When connecting radiator cap to the radiator cap tester (commercial service tool) (A) and the radiator cap tester adapter (commercial service tool) (B), apply engine coolant to the cap seal surface.

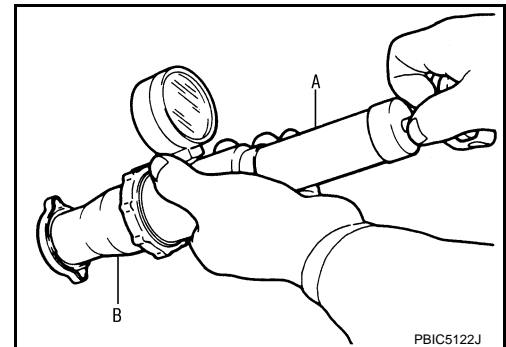

- Replace radiator cap if there is an unusualness related to the above three.

CAUTION:

When installing radiator cap, thoroughly wipe out the radiator filler neck to remove any waxy residue or foreign material.

RADIATOR

RADIATOR : Inspection

INFOID:000000005491484

Check radiator for mud or clogging. If necessary, clean radiator as follows.

CAUTION:

- **Be careful not to bend or damage radiator fins.**
 - **When radiator is cleaned without removal, remove all surrounding parts such as radiator cooling fan assembly and horns. Then tape harness and harness connectors to prevent water from entering.**
1. Apply water by hose to the back side of the radiator core vertically downward.
 2. Apply water again to all radiator core surfaces once per minute.
 3. Stop washing if any stains no longer flow out from radiator.

RADIATOR

< PERIODIC MAINTENANCE >

4. Blow air into the back side of radiator core vertically downward.
 - Use compressed air lower than 490 kPa (5 kg/cm², 71 psi) and keep distance more than 30 cm (11.81 in).
5. Blow air again into all the radiator core surfaces once per minute until no water sprays out.

A

CO

C

D

E

F

G

H

I

J

K

L

M

N

O

P

RADIATOR

< REMOVAL AND INSTALLATION >

REMOVAL AND INSTALLATION

RADIATOR

Exploded View

INFOID:000000005491485

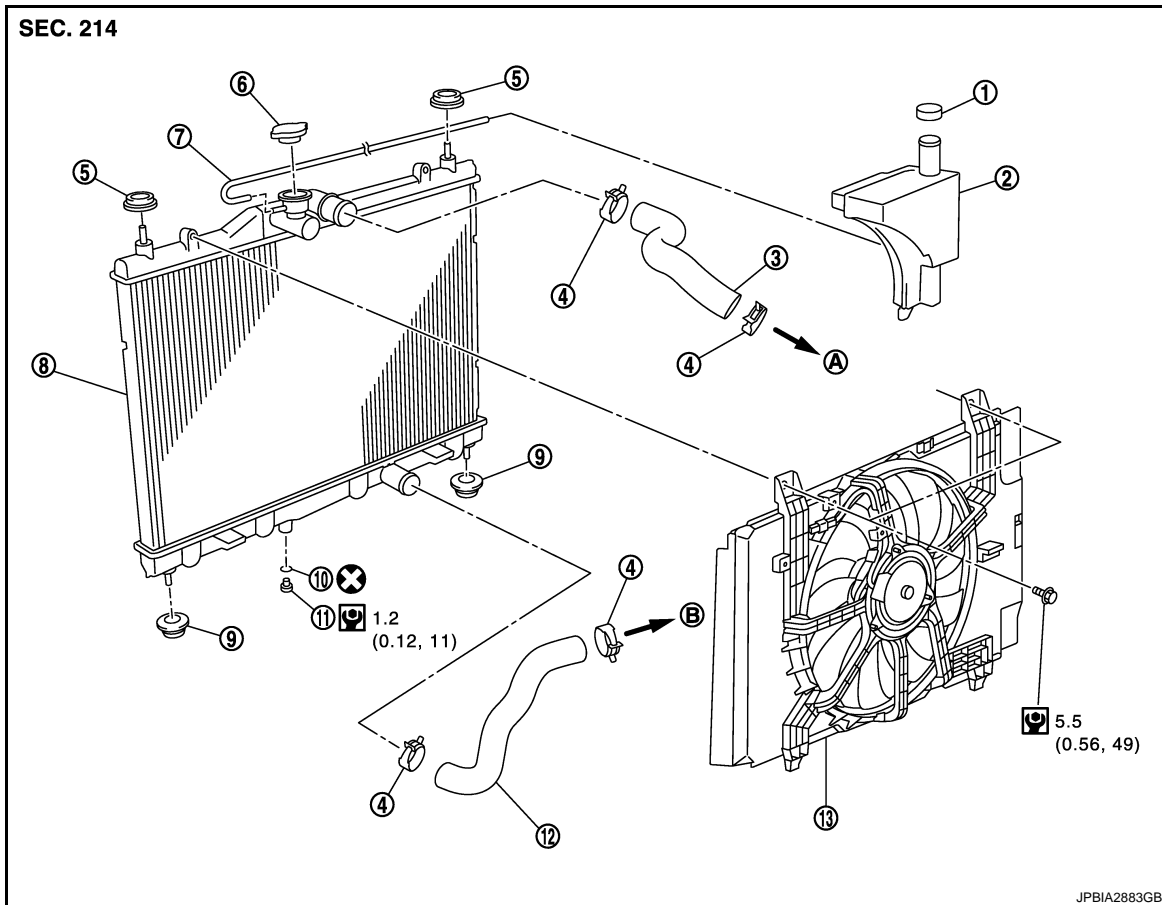

- | | | |
|--------------------------|----------------------------|----------------------------|
| 1. Reservoir tank cap | 2. Reservoir tank | 3. Radiator hose (upper) |
| 4. Clamp | 5. Mounting rubber (upper) | 6. Radiator cap |
| 7. Reservoir tank hose | 8. Radiator | 9. Mounting rubber (lower) |
| 10. O-ring | 11. Drain plug | 12. Radiator hose (lower) |
| 13. Cooling fan assembly | | |
- A. To water outlet B. To water inlet

Refer to [GI-4, "Components"](#) for symbols in the figure.

Removal and Installation

INFOID:000000005491486

REMOVAL

WARNING:

- Never remove radiator cap when engine is hot. Serious burns may occur from high-pressure engine coolant escaping from radiator.
- Wrap a thick cloth around the radiator cap. Slowly turn it a quarter of a turn to release built-up pressure. Then turn it all the way.

1. Drain engine coolant from radiator. Refer to [CO-9, "Draining"](#).

CAUTION:

- Perform this step when the engine is cold.
 - Never spill engine coolant on drive belt.
2. Remove air duct (inlet) and resonator assembly. Refer to [EM-24, "Exploded View"](#).

RADIATOR

< REMOVAL AND INSTALLATION >

3. Remove reservoir tank as follows:
 - a. Disconnect reservoir tank hose.
 - b. Release the tab (A) in the direction shown by the arrow (←).
 - c. Lift up and remove the reservoir tank with tab released.

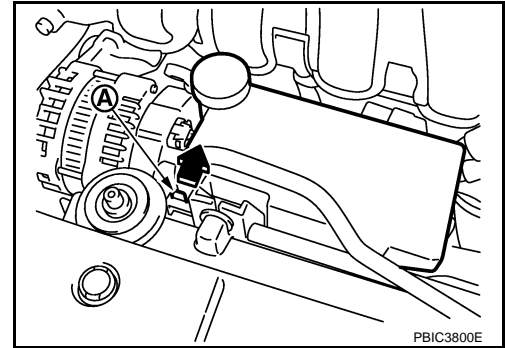

4. Remove radiator hose (upper and lower).
5. Disconnect harness connector from fan motor, and move harness aside.
6. Remove cooling fan assembly.
CAUTION:
Be careful not to damage or scratch the radiator core.
7. Remove the following parts.
 - Front grille assembly: Refer to [EXT-18, "Exploded View"](#).
 - Front bumper fascia assembly: Refer to [EXT-12, "Exploded View"](#).
 - Front combination lamp assembly (RH and LH): Refer to [EXL-208, "Exploded View"](#).
8. Remove radiator core support (upper). Refer to [DLK-182, "Exploded View"](#) (WITH INTELLIGENT KEY STSTEM) or [DLK-330, "Exploded View"](#) (WITHOUT INTELLIGENT KEY STSTEM).
9. Pull up and remove the radiator assembly (1).

2 : Condenser assembly

← : Vehicle front

CAUTION:
Be careful not to damage radiator core and condenser assembly core.

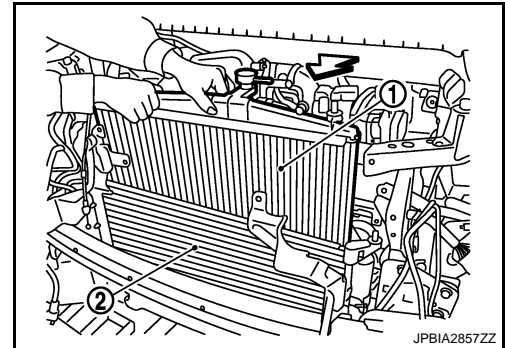

INSTALLATION

Install in the reverse order of removal.

Inspection

INFOID:000000005491487

INSPECTION AFTER INSTALLATION

- Check for leakage of engine coolant using the radiator cap tester adapter (commercial service tool) and the radiator cap tester (commercial service tool). Refer to [CO-9, "Inspection"](#).
- Start and warm up the engine. Check visually that there is no leakage of engine coolant.

COOLING FAN

< REMOVAL AND INSTALLATION >

Note the following, and install in the reverse order of removal.

CAUTION:

Only use genuine parts for fan shroud mounting bolt and observe the specified torque (to prevent radiator from being damaged).

NOTE:

Cooling fan is controlled by ECM. For details, refer to [EC-61, "System Diagram"](#).

Disassembly and Assembly

INFOID:000000005491490

DISASSEMBLY

1. Remove cooling fan mounting nut, and then remove the cooling fan.
2. Remove fan motor.

ASSEMBLY

Note the following, and assemble in the reverse order of disassembly.

- Apply genuine high strength thread locking sealant on fan motor shaft.

Inspection

INFOID:000000005491491

INSPECTION AFTER DISASSEMBLY

Cooling Fan

Inspect cooling fan for crack or unusual bend.

- If anything is found, replace cooling fan.

A
CO
C
D
E
F
G
H
I
J
K
L
M
N
O
P

WATER PUMP

< REMOVAL AND INSTALLATION >

INSPECTION AFTER INSTALLATION

- Check for leakage of engine coolant using the radiator cap tester adapter (commercial service tool) and the radiator cap tester (commercial service tool). Refer to [CO-9, "Inspection"](#).
- Start and warm up the engine. Check visually that there is no leakage of engine coolant.

A

CO

C

D

E

F

G

H

I

J

K

L

M

N

O

P

THERMOSTAT

< REMOVAL AND INSTALLATION >

THERMOSTAT

Exploded View

INFOID:000000005491495

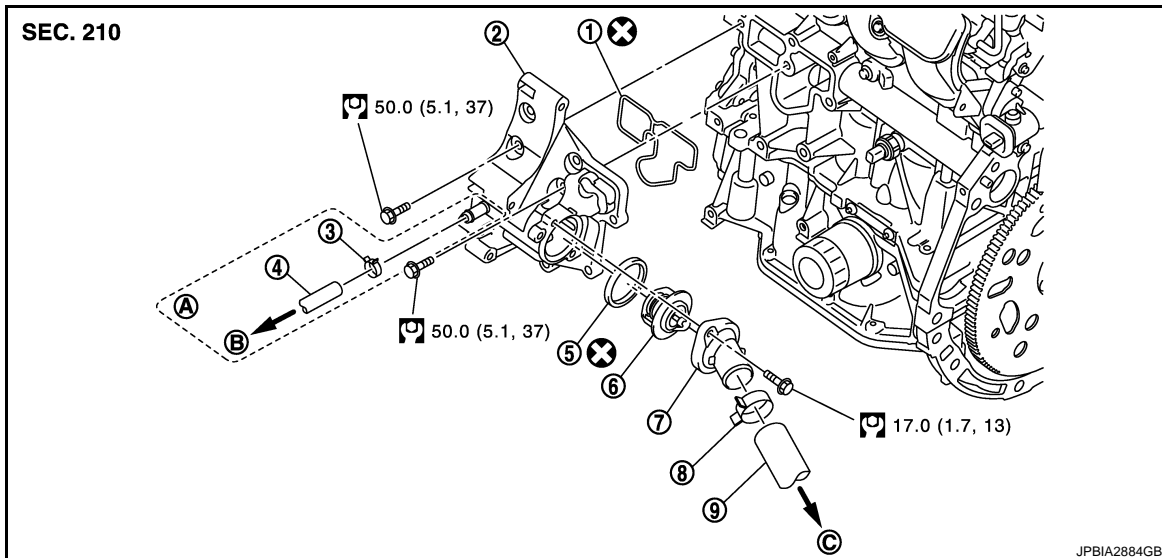

- | | | |
|----------------|------------------------|--------------------------|
| 1. Gasket | 2. Thermostat housing | 3. Clamp |
| 4. Water hose | 5. Rubber ring | 6. Thermostat |
| 7. Water inlet | 8. Clamp | 9. Radiator hose (lower) |
| A. CVT models | B. To CVT fluid cooler | C. To radiator |

Refer to [GI-4, "Components"](#) for symbols in the figure.

Removal and Installation

INFOID:000000005491496

REMOVAL

1. Drain engine coolant from radiator. Refer to [CO-9, "Draining"](#).
CAUTION:
Perform this step when engine is cold.
2. Remove air duct (inlet) and resonator assembly. Refer to [EM-24, "Exploded View"](#).
3. Add paint mark, then disconnect radiator hose (lower) from water inlet. Refer to [CO-14, "Exploded View"](#).
4. Remove water inlet and thermostat.
 - Engine coolant leakage from cylinder block, so have a receptacle ready below.
5. Remove thermostat housing with the following procedure:
 - a. Remove A/C compressor with A/C piping connected, and temporarily fasten it on vehicle with a rope. Refer to [HA-31, "Exploded View"](#). (Models with A/C)
 - b. Remove water pump. Refer to [CO-18, "Exploded View"](#).
 - c. Remove alternator. Refer to [CHG-24, "Exploded View"](#).

INSTALLATION

Note the following, and install in the reverse order of removal.

Thermostat

THERMOSTAT

< REMOVAL AND INSTALLATION >

- Install thermostat with making rubber ring (1) groove fit to thermostat flange (A) with the whole circumference.

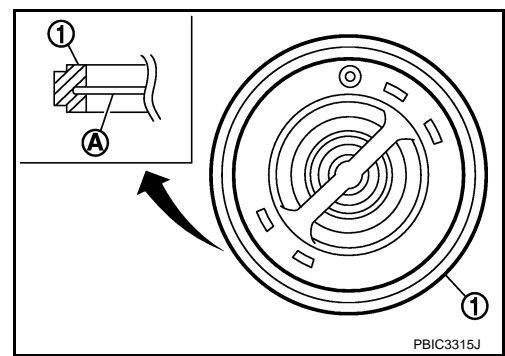

- Install thermostat (1) with jiggle valve (A) facing upwards.

2 : Thermostat housing

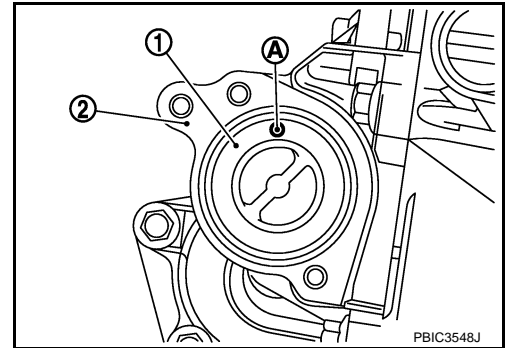

Inspection

INFOID:000000005491497

INSPECTION AFTER REMOVAL

Thermostat

- Place a thread (A) so that it is caught in the valves of thermostat (1). Immerse fully in a container (B) filled with water. Heat while stirring.
- The valve opening temperature is the temperature at which the valve opens and falls from the thread.
- Continue heating. Check the full open valve lift amount.
- After checking the maximum valve lift amount, lower the water temperature and check the valve closing temperature.

Standard: Refer to [CO-24, "Thermostat"](#).

- If out of the standard, replace thermostat.

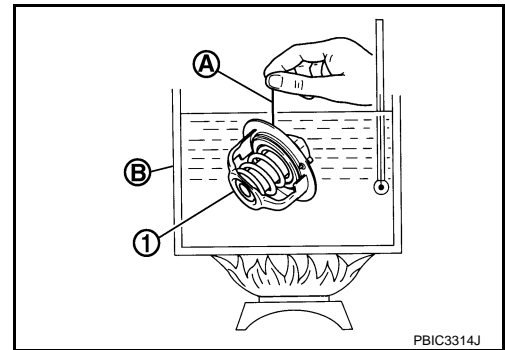

INSPECTION AFTER INSTALLATION

- Check for leakage of engine coolant using the radiator cap tester adapter (commercial service tool) and the radiator cap tester (commercial service tool). Refer to [CO-9, "Inspection"](#).
- Start and warm up the engine. Check visually that there is no leakage of engine coolant.

WATER OUTLET

< REMOVAL AND INSTALLATION >

WATER OUTLET

Exploded View

INFOID:000000005491498

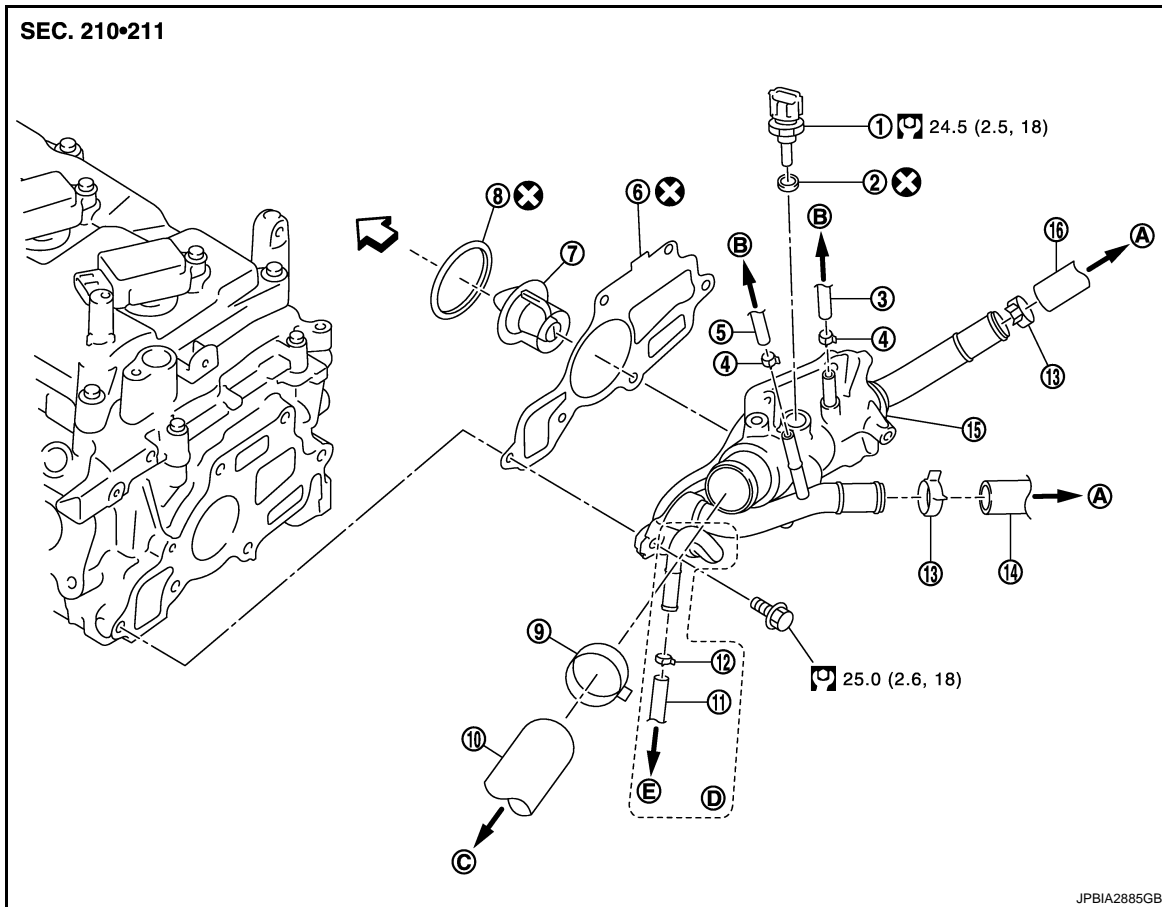

- | | | |
|--------------------------------------|--|------------------|
| 1. Engine coolant temperature sensor | 2. Washer | 3. Water hose |
| 4. Clamp | 5. Water hose | 6. Gasket |
| 7. Water control valve | 8. Rubber ring | 9. Clamp |
| 10. Radiator hose (upper) | 11. Water hose | 12. Clamp |
| 13. Clamp | 14. Heater hose | 15. Water outlet |
| 16. Heater hose | | |
| A. To heater | B. To electric throttle control actuator | C. To radiator |
| D. CVT models | E. To CVT fluid cooler | |

← : Engine front

Refer to [GI-4, "Components"](#) for symbols in the figure.

Removal and Installation

INFOID:000000005491499

REMOVAL

- Drain engine coolant from radiator. Refer to [CO-9, "Draining"](#).
CAUTION:
 - Perform this step when engine is cold.
 - Never spill engine coolant on drive belt.
- Remove air duct (inlet) and resonator assembly and each air ducts. Refer to [EM-24, "Exploded View"](#).
- Disconnect radiator hose (upper). Refer to [CO-14, "Exploded View"](#).
- Disconnect harness connector from engine coolant temperature sensor.
- Remove water hoses.

WATER OUTLET

< REMOVAL AND INSTALLATION >

6. Remove heater hoses.
7. Remove water outlet.
8. Remove engine coolant temperature sensor from water outlet, if necessary.

INSTALLATION

Note the following, and install in the reverse order of removal.

- Install water control valve with making rubber ring (1) groove fit to water control valve flange (A) with the whole circumference.

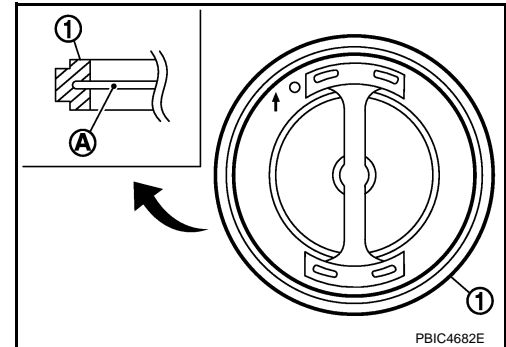

- Install water control valve (2) with the arrow (A) facing up and the frame center part (B) facing upwards.

1 : Water outlet

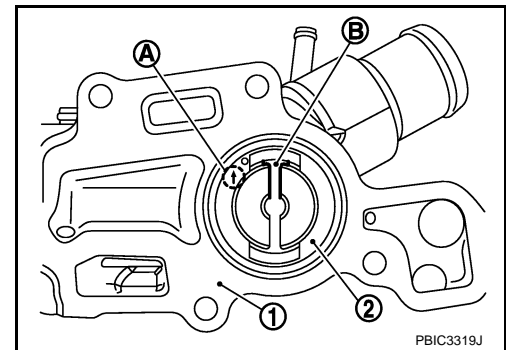

Inspection

INFOID:000000005491500

INSPECTION AFTER REMOVAL

Water Control Valve

- Place a thread (A) so that it is caught in the valves of water control valve (1). Immerse fully in a container (B) filled with water. Heat while stirring.
- The valve opening temperature is the temperature at which the valve opens and falls from the thread.
- Continue heating. Check the continuous valve lifting toward maximum valve lift.

NOTE:

The maximum valve lift amount standard temperature for water control valve is the reference value.

- After checking the maximum valve lift amount, lower the water temperature and check the valve closing temperature.

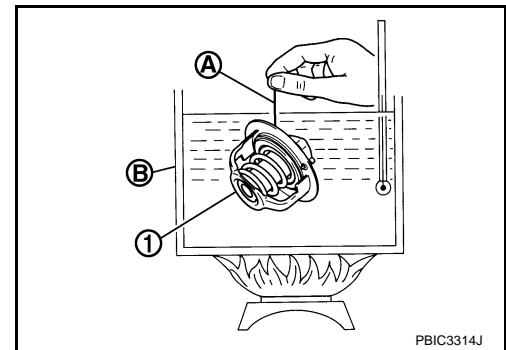

Standard: Refer to [CO-24, "Water Control Valve"](#).

- If out of the standard, replace water control valve.

INSPECTION AFTER INSTALLATION

- Check for leakage of engine coolant using the radiator cap tester adapter (commercial service tool) and the radiator cap tester (commercial service tool). Refer to [CO-9, "Inspection"](#).
- Start and warm up the engine. Check visually that there is no leakage of engine coolant.

SERVICE DATA AND SPECIFICATIONS (SDS)

< SERVICE DATA AND SPECIFICATIONS (SDS)

SERVICE DATA AND SPECIFICATIONS (SDS)

SERVICE DATA AND SPECIFICATIONS (SDS)

Periodical Maintenance Specification

INFOID:000000005491501

ENGINE COOLANT CAPACITY (APPROXIMATE)

Unit: ℓ (US qt, Imp qt)

Engine coolant capacity (With reservoir tank at "MAX" level)	CVT models	7.1 (7-1/2, 6-1/4)
	M/T models	6.8 (7-1/4, 6)
Reservoir tank engine coolant capacity (At "MAX" level)		0.7 (3/4, 5/8)

Radiator

INFOID:000000005491502

Unit: kPa (kg/cm², psi)

Cap relief pressure	Standard	78 - 98 (0.8 - 1.0, 11 - 14)
	Limit	59 (0.6, 9)
Leakage testing pressure		98 (1.0, 14)

Thermostat

INFOID:000000005491503

Standard

Valve opening temperature	80.5 - 83.5°C (177 - 182°F)
Maximum valve lift	8.0 mm/95°C (0.315 in/203°F)
Valve closing temperature	77°C (171°F)

Water Control Valve

INFOID:000000005491504

Standard

Valve opening temperature	93.5 - 96.5°C (200 - 206°F)
Maximum valve lift	8.0 mm/108°C (0.315 in/226°F)
Valve closing temperature	90°C (194°F)